

LONGITUDINAL BEAM DYNAMICS

Elias Métral (CERN BE Department)

The present transparencies are inherited from Frank Tecker (CERN-BE), who gave this course in 2010 (I already gave this course in 2011-12-13) and who inherited them from Roberto Corsini (CERN-BE), who gave this course in the previous years, based on the ones written by Louis Rinolfi (CERN-BE) who held the course at JUAS from 1994 to 2002 (see CERN/PS 2000-008 (LP)):

<http://cdsweb.cern.ch/record/446961/files/ps-2000-008.pdf>

Material from Joel LeDuff's Course at the CERN Accelerator School held at Jyväskylä, Finland the 7-18 September 1992 (CERN 94-01) has been used as well:

<http://cdsweb.cern.ch/record/235242/files/p253.pdf>

<http://cdsweb.cern.ch/record/235242/files/p289.pdf>

I attended the course given by Louis Rinolfi in 1996 and was his assistant in 2000 and 2001 (and the assistant of Michel Martini for his course on transverse beam dynamics)

This course and related exercises / exams (as well as other courses) can be found in my web page: <http://emetral.web.cern.ch/emetral/>

New assistant this year: Elena Benedetto (CERN BE Department)

8 Lectures

4 Tutorials

Fields & Forces

Relativity

Acceleration (electrostatic, RF)

Synchrotrons

Longitudinal phase space

Momentum Compaction

Transition energy

Synchrotron oscillations

+ RF manipulations and the ESME simulation code

=> Added to the past slides

**Examination: WE 05/02/2014
(09:00 to 10:30)**

WEEK 2

	Monday Jan 13 th	Tuesday Jan 14 th	Wednesday Jan 15 th	Thursday Jan 16 th	Friday Jan 17 th	
09:00	Transverse Dynamics lecture <i>A. Latina</i>	Longitudinal Dynamics lecture <i>E. Métral</i>	Transverse Dynamics lecture <i>A. Latina</i>	Transverse Dynamics lecture <i>A. Latina</i>	Longitudinal Dynamics lecture <i>E. Métral</i>	09:00
10:00	<p style="color: red; text-align: center;">Bus leaves at 10h from JUAS</p> <p style="color: green; text-align: center;">(Lunch at ESRF)</p> <p style="text-align: center;">VISIT OF ESRF</p> <p style="color: red; text-align: center;">Return scheduled at 20h00</p>	Coffee Break	Coffee Break	Coffee Break	Coffee Break	10:00
10:15		Longitudinal Dynamics tutorial <i>E. Métral</i>	Longitudinal Dynamics lecture <i>E. Métral</i>	Longitudinal Dynamics lecture <i>E. Métral</i>	Longitudinal Dynamics lecture <i>E. Métral</i>	10:15
11:15		Transverse Dynamics lecture <i>A. Latina</i>	Longitudinal Dynamics tutorial <i>E. Métral</i>	Longitudinal Dynamics lecture <i>E. Métral</i>	Longitudinal Dynamics tutorial <i>E. Métral</i>	11:15
12:15		LUNCH	LUNCH	LUNCH	LUNCH	12:15
14:00		Exercises in computer room		Exercises in computer room		14:00
15:00		Transverse Dynamics tutorial <i>A. Latina / J. Resta Lopez</i>	Longitudinal Dynamics lecture <i>E. Métral</i>	Transverse Dynamics lecture on LHC <i>R. Alemany</i>	Longitudinal Dynamics tutorial <i>E. Métral</i>	15:00
16:00		Longitudinal Dynamics lecture <i>E. Métral</i>	Transverse Dynamics lecture <i>A. Latina</i>	Transverse Dynamics tutorial <i>A. Latina / J. Resta Lopez</i>	Transverse Dynamics lecture <i>A. Latina</i>	16:00
16:15		Coffee Break	Coffee Break	Coffee Break	Coffee Break	16:15
17:15		Intro. to MADX <i>G. Sterbini</i>	MADX <i>A. Latina / G. Sterbini</i>	MADX <i>A. Latina / G. Sterbini</i>	Transverse Dynamics tutorial <i>A. Latina / J. Resta Lopez</i>	17:15

LESSON I

Fields & forces

Acceleration by time-varying fields

Relativistic equations

Equation of motion for a particle of charge q

$$\vec{F} = \frac{d\vec{p}}{dt} = q \left(\vec{E} + \vec{v} \times \vec{B} \right)$$

$$\vec{p} = m \vec{v}$$

Momentum

$$\vec{v}$$

Velocity

$$\vec{E}$$

Electric field

$$\vec{B}$$

Magnetic field

The fields must satisfy Maxwell's equations

The integral forms, in vacuum, are recalled below:

1. Gauss's law
(electrostatic)

$$\int_S \vec{E} \cdot d\vec{s} = \frac{1}{\epsilon_0} \int_V \rho \, dV$$

2. No free magnetic poles
(magnetostatic)

$$\int_S \vec{B} \cdot d\vec{s} = 0$$

3. Ampere's law
(modified by Gauss)
(electric varying)

$$\int_L \vec{B} \cdot d\vec{l} = \mu_0 \int_S \vec{j} \cdot d\vec{s} + \frac{1}{c^2} \int_S \frac{\partial \vec{E}}{\partial t} \cdot d\vec{s}$$

4. Faraday's law
(magnetic varying)

$$\int_L \vec{E} \cdot d\vec{l} = - \int_S \frac{\partial \vec{B}}{\partial t} \cdot d\vec{s}$$

Maxwell's equations

The differential forms, in vacuum, are recalled below:

1. Gauss's law

$$\nabla \cdot \vec{E} = \frac{1}{\epsilon_0} \rho(\vec{r}, t)$$

2. No free magnetic poles

$$\nabla \cdot \vec{B} = 0$$

3. Ampere's law
(modified by Gauss)

$$\nabla \times \vec{B} = \mu_0 \vec{j}(\vec{r}, t) + \frac{1}{c^2} \frac{\partial \vec{E}}{\partial t}$$

4. Faraday's law

$$\nabla \times \vec{E} = -\frac{\partial \vec{B}}{\partial t}$$

Constant electric field

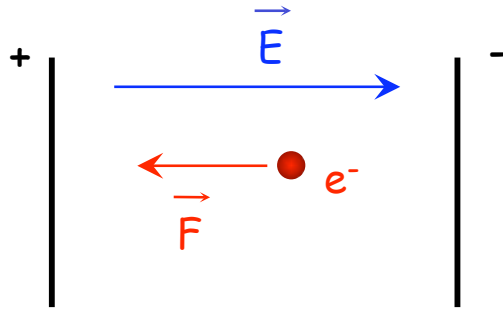

$$\frac{d\vec{p}}{dt} = -e \vec{E}$$

1. Direction of the force always parallel to the field
2. Trajectory can be modified, velocity also \Rightarrow momentum and energy can be modified

This force can be used to accelerate and decelerate particles

Constant magnetic field

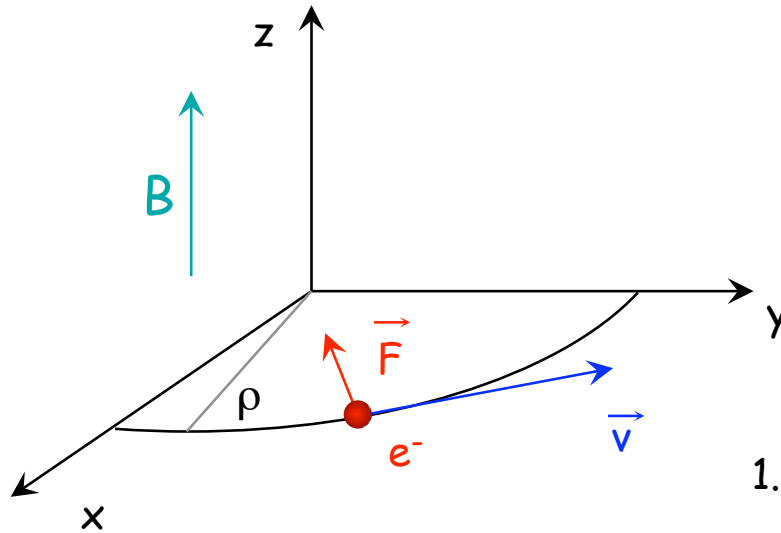

$$\frac{d\vec{p}}{dt} = \vec{F} = -e (\vec{v} \times \vec{B})$$

1. Direction always perpendicular to the velocity
2. Trajectory can be modified, but not the velocity

$$e v B = \frac{m v^2}{\rho}$$

This force **cannot** modify the energy

magnetic rigidity: $B \rho = \frac{p}{e}$

angular frequency: $\omega = 2\pi f = \frac{e}{m} B$

Application: spectrometer

Important relationship:

$$B \rho = \frac{p}{e} \quad \rightarrow \quad \rho = \frac{p}{eB}$$

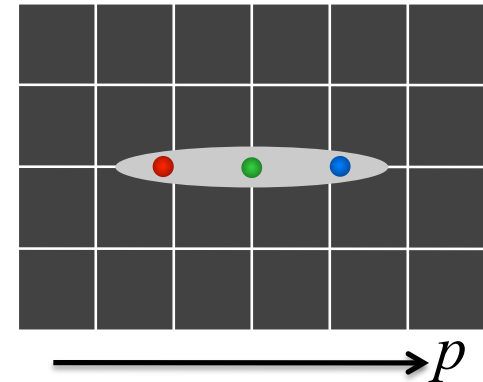
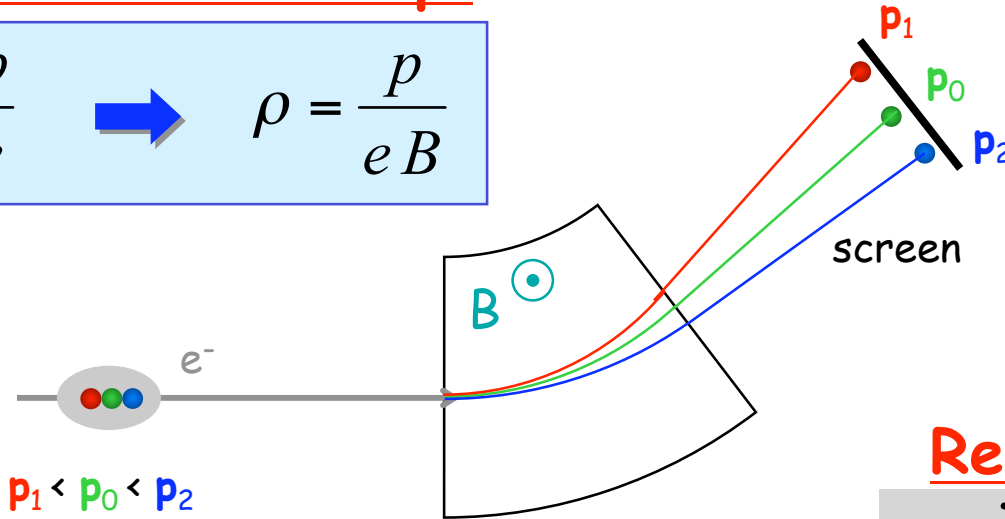

Real life example: CTF3

Time-resolved spectrum

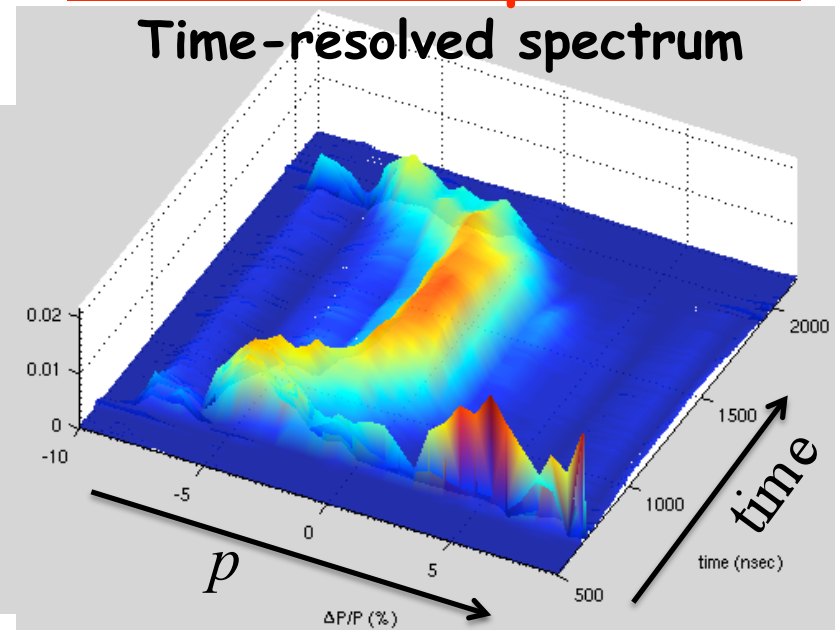
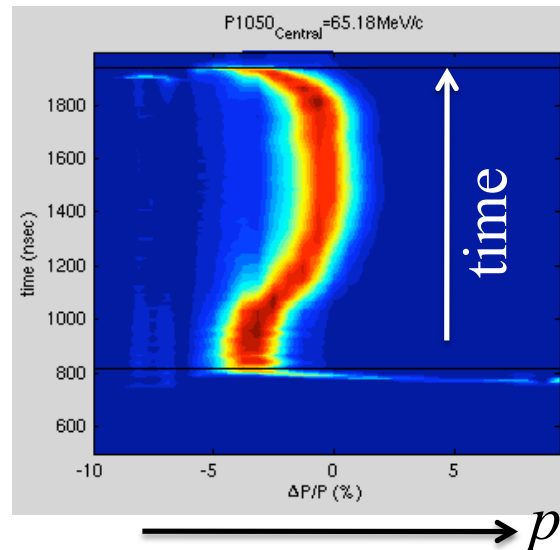

Practical units:

$$B \rho [\text{Tm}] \approx \frac{p [\text{GeV}/c]}{0.3}$$

Larmor formula

An accelerating charge radiates a power P given by:

$$P = \frac{2}{3} \frac{r_e}{m_0 c} \left\{ \dot{p}_{//}^2 + \gamma^2 \dot{p}_{\perp}^2 \right\}$$

Acceleration in the direction of the particle motion

Acceleration perpendicular to the particle motion



"Synchrotron radiation"

Energy lost on a trajectory L

$$W = \int_L \frac{P}{v} ds$$



For electrons in a constant magnetic field:

$$W [\text{eV/turn}] = 88 \cdot 10^3 \frac{E^4 [\text{GeV}]}{\rho [\text{m}]}$$

Comparison of magnetic and electric forces

$$|\vec{B}| = 1 \text{ T}$$

$$|\vec{E}| = 10 \text{ MV/m}$$

$$\frac{F_{MAGN}}{F_{ELEC}} = \frac{evB}{eE} = \beta c \frac{B}{E} \cong 3 \cdot 10^8 \frac{1}{10^7} \beta = 30 \beta$$

Acceleration by time-varying magnetic field

A variable magnetic field produces an electric field (Faraday's Law):

$$\int_L \vec{E} \cdot d\vec{l} = - \int_S \frac{\partial \vec{B}}{\partial t} \cdot d\vec{s} = - \frac{d\Phi}{dt}$$

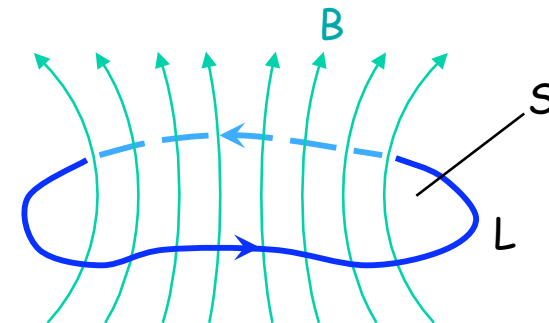

It is the **Betatron** concept

The varying magnetic field is used to guide particles on a circular trajectory as well as for acceleration

Betatron

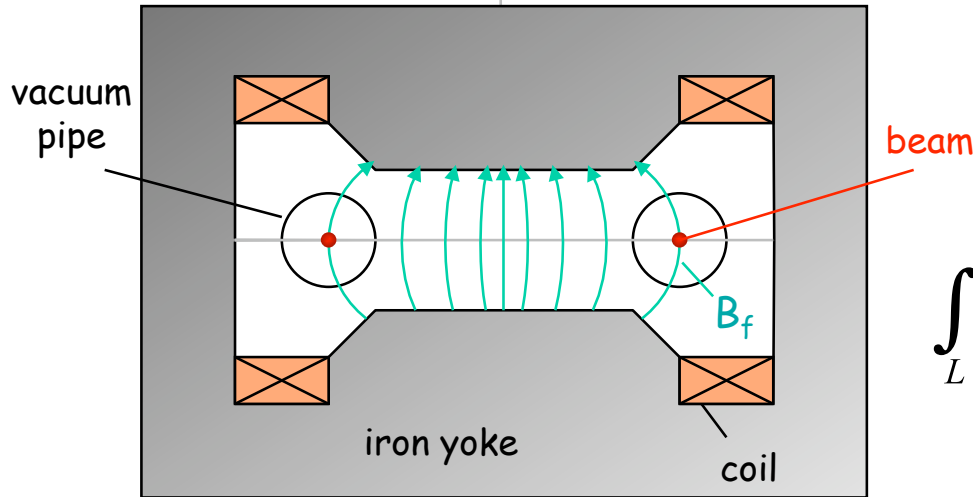

$$\int_L \vec{E} \cdot d\vec{l} = 2\pi R E = -\frac{d\Phi}{dt} = -\pi R^2 \frac{dB_{ave}}{dt}$$

$$\frac{dp}{dt} = e E = \frac{1}{2} e R \frac{dB_{ave}}{dt}$$

$$B \rho = \frac{p}{e} \quad \rightarrow \quad \frac{dp}{dt} = e R \frac{dB_f}{dt}$$



$$B_f = \frac{1}{2} B_{ave} + const.$$

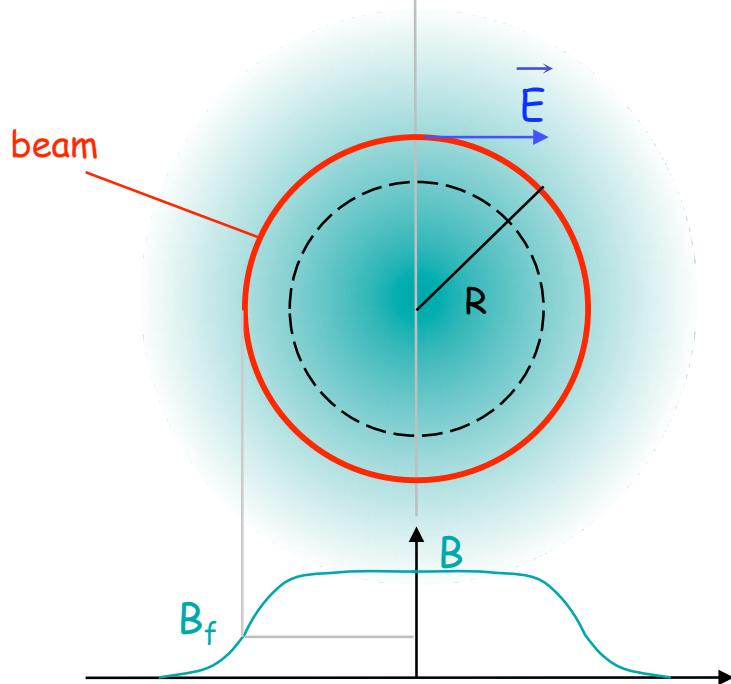

Acceleration by time-varying electric field

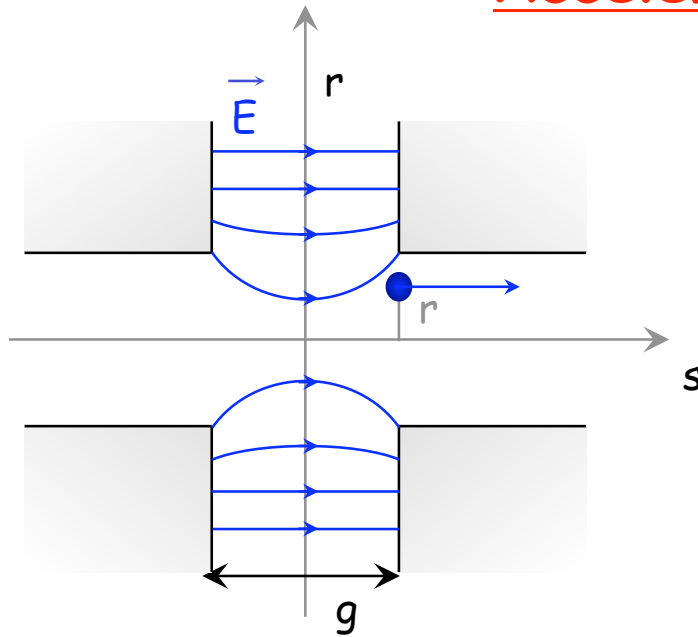

- Let V_{RF} be the amplitude of the RF voltage across the gap g
- The particle crosses the gap at a distance r
- The energy gain is:

$$\Delta E = e \int_{-g/2}^{g/2} \vec{E}(s, r, t) d\vec{s}$$

[MeV]

[n]

[MV/m]

(1 for electrons or protons)

In the cavity gap, the electric field is supposed to be:

$$E(s, r, t) = E_1(s, r) \cdot E_2(t)$$

In general, $E_2(t)$ is a sinusoidal time variation with angular frequency ω_{RF}

$$E_2(t) = E_0 \sin \Phi(t) \quad \text{where} \quad \Phi(t) = \int_{t_0}^t \omega_{RF} dt + \Phi_0$$

Convention

1. For circular accelerators, the origin of time is taken at the **zero crossing** of the RF voltage with positive slope
2. For linear accelerators, the origin of time is taken at the positive **crest** of the RF voltage

Time $t = 0$ chosen such that:

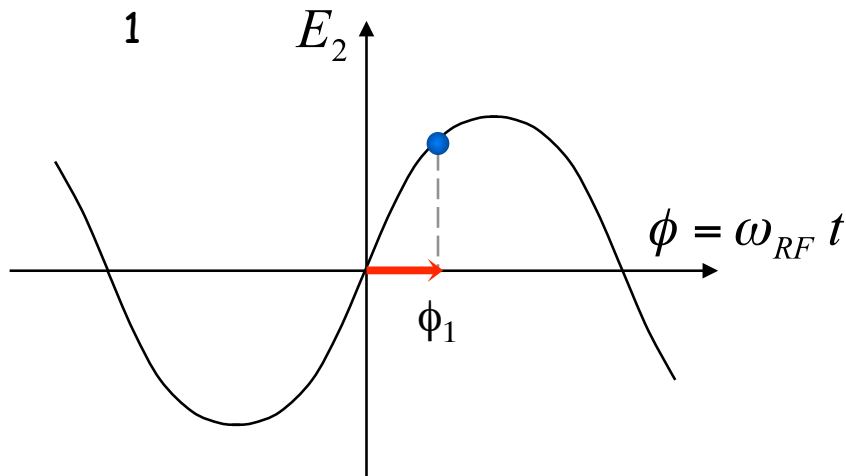

$$E_2(t) = E_0 \sin(\omega_{RF} t)$$

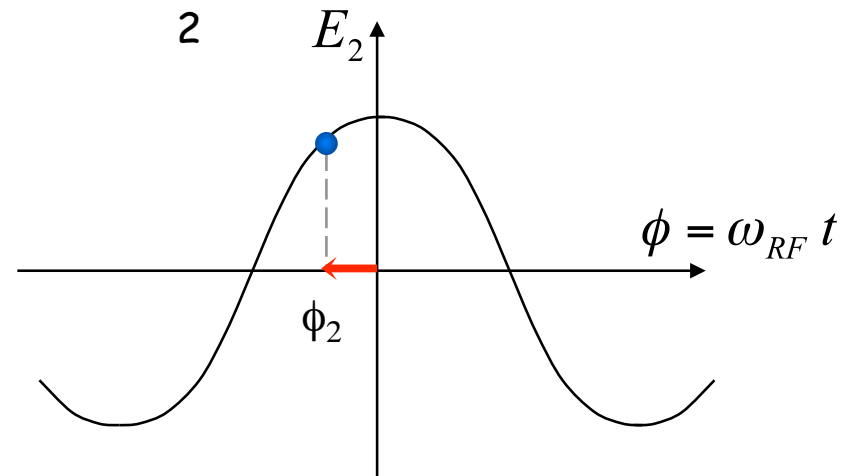

$$E_2(t) = E_0 \cos(\omega_{RF} t)$$

Relativistic Equations

$$E = mc^2$$

normalized velocity

$$\beta = \frac{v}{c} = \sqrt{1 - \frac{1}{\gamma^2}}$$

total energy
rest energy

$$\gamma = \frac{E}{E_0} = \frac{m}{m_0} = \frac{1}{\sqrt{1 - \frac{v^2}{c^2}}} = \frac{1}{\sqrt{1 - \beta^2}}$$

energy

$$E = E_{kin} + E_0$$

total kinetic rest

momentum

$$p = mv = \beta \frac{E}{c} = \beta \gamma m_0 c$$

energy	momentum	mass
eV	eV/c	eV/c ²

$$p^2 c^2 = E^2 - E_0^2 \qquad \gamma = 1 + \frac{E_{kin}}{E_0}$$

$$p [\text{GeV}/c] \cong 0.3 B [\text{T}] \rho [\text{m}]$$

First derivatives

$$d\beta = \beta^{-1} \gamma^{-3} d\gamma$$

$$d(cp) = E_0 \gamma^3 d\beta$$

$$d\gamma = \beta (1 - \beta^2)^{3/2} d\beta$$

Logarithmic derivatives

$$\frac{d\beta}{\beta} = (\beta \gamma)^{-2} \frac{d\gamma}{\gamma}$$

$$\frac{dp}{p} = \frac{\gamma^2}{\gamma^2 - 1} \frac{dE}{E} = \frac{\gamma}{\gamma + 1} \frac{dE_{kin}}{E_{kin}}$$

$$\frac{d\gamma}{\gamma} = (\gamma^2 - 1) \frac{d\beta}{\beta}$$

LESSON II

An overview of particle acceleration

Transit time factor

Main RF parameters

Momentum compaction

Transition energy

Relativistic Equations

$$E = m c^2$$

normalized velocity

$$\beta = \frac{v}{c} = \sqrt{1 - \frac{1}{\gamma^2}}$$

total energy
rest energy

$$\gamma = \frac{E}{E_0} = \frac{m}{m_0} = \frac{1}{\sqrt{1 - \frac{v^2}{c^2}}} = \frac{1}{\sqrt{1 - \beta^2}}$$

energy

$$E = E_{kin} + E_0$$

total kinetic rest

momentum

$$p = mv = \beta \frac{E}{c} = \beta \gamma m_0 c$$

energy	momentum	mass
eV	eV/c	eV/c ²

$$p^2 c^2 = E^2 - E_0^2 \qquad \gamma = 1 + \frac{E_{kin}}{E_0}$$

$$p [\text{GeV}/c] \cong 0.3 B [\text{T}] \rho [\text{m}]$$

normalized velocity

$$\beta = \frac{v}{c} = \sqrt{1 - \frac{1}{\gamma^2}}$$

total energy
rest energy

$$\gamma = \frac{E}{E_0} = \frac{m}{m_0} = \frac{1}{\sqrt{1 - \frac{v^2}{c^2}}} = \frac{1}{\sqrt{1 - \beta^2}}$$

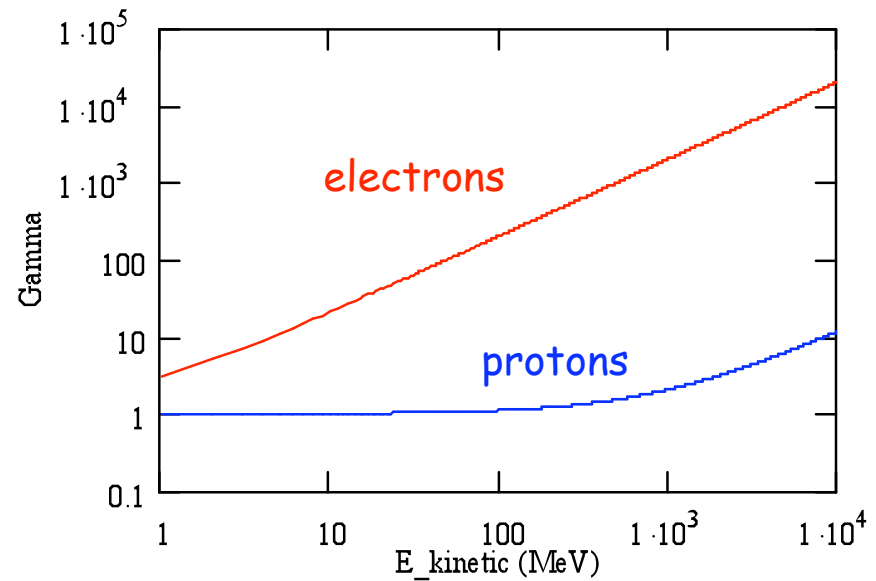
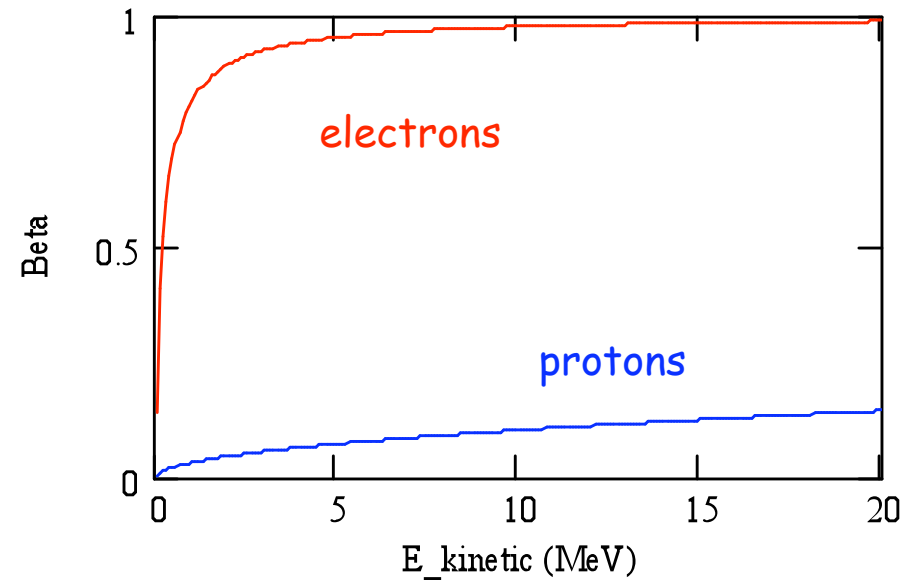

Electrostatic accelerators

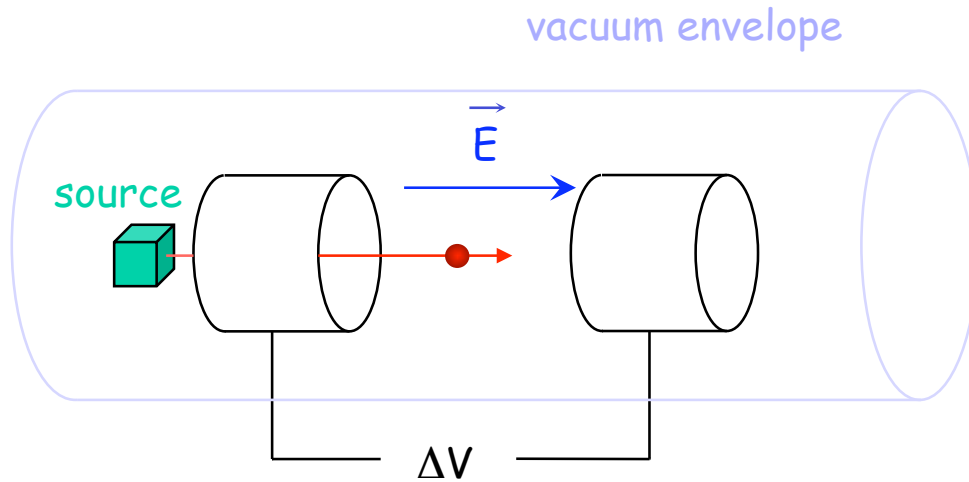

- The potential difference between two electrodes is used to accelerate particles
- Limited in energy by the maximum high voltage (~ 10 MV)
- Present applications: x-ray tubes, low energy ions, electron sources (thermionic guns)

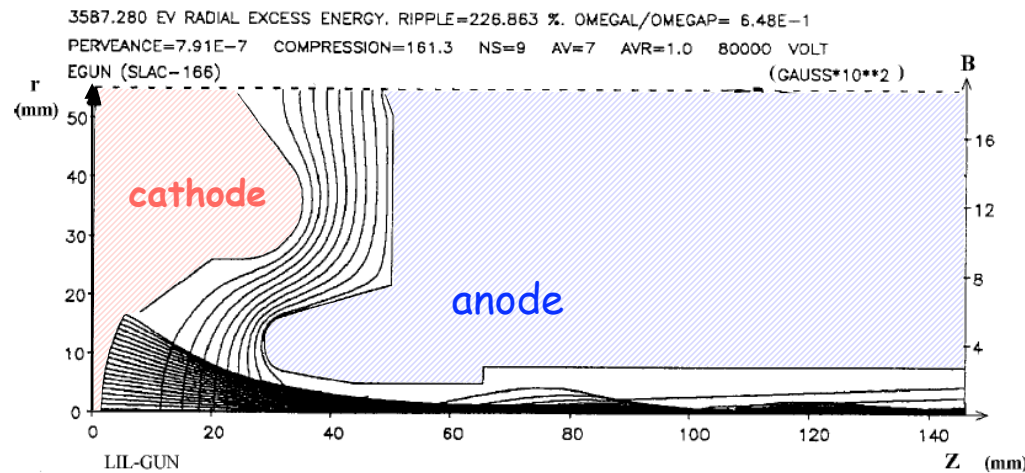

Electric field potential and beam trajectories inside an electron gun (LEP Injector Linac at CERN), computed with the code E-GUN

Electrostatic accelerator
Protons & Ions



Alvarez structure

Used for protons, ions (50 - 200 MeV, $f \sim 200$ MHz)

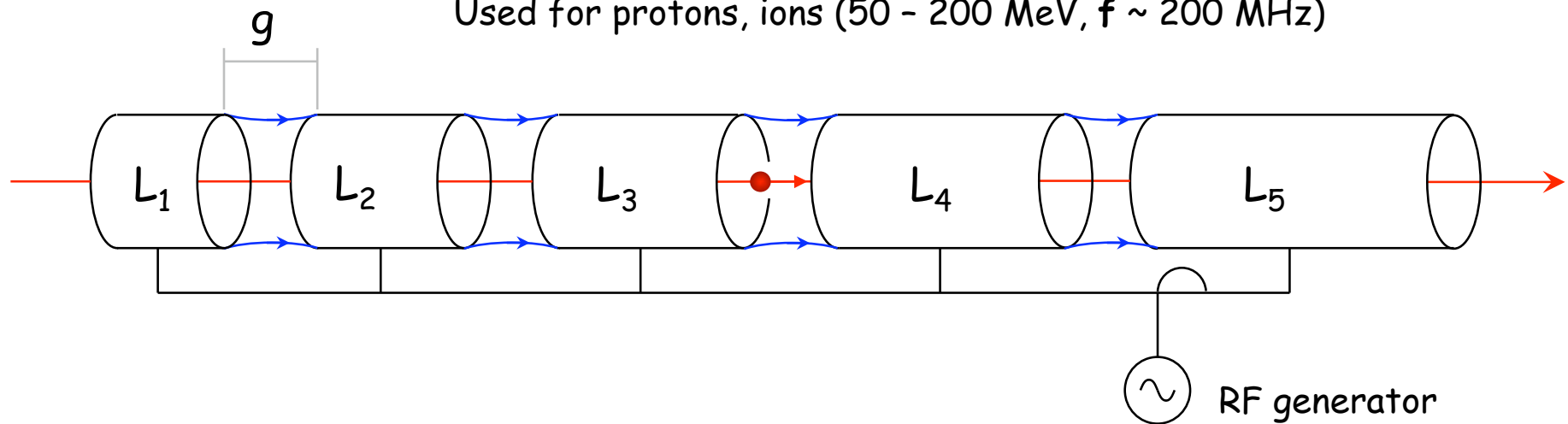

Synchronism condition ($g \ll L$)



$$L = v_s T_{RF} = \beta_s \lambda_{RF}$$

$$\omega_{RF} = 2\pi \frac{v_s}{L}$$

Proton and ion linacs
(Alvarez structure)

LINAC 1 (CERN)

© CERN Geneva

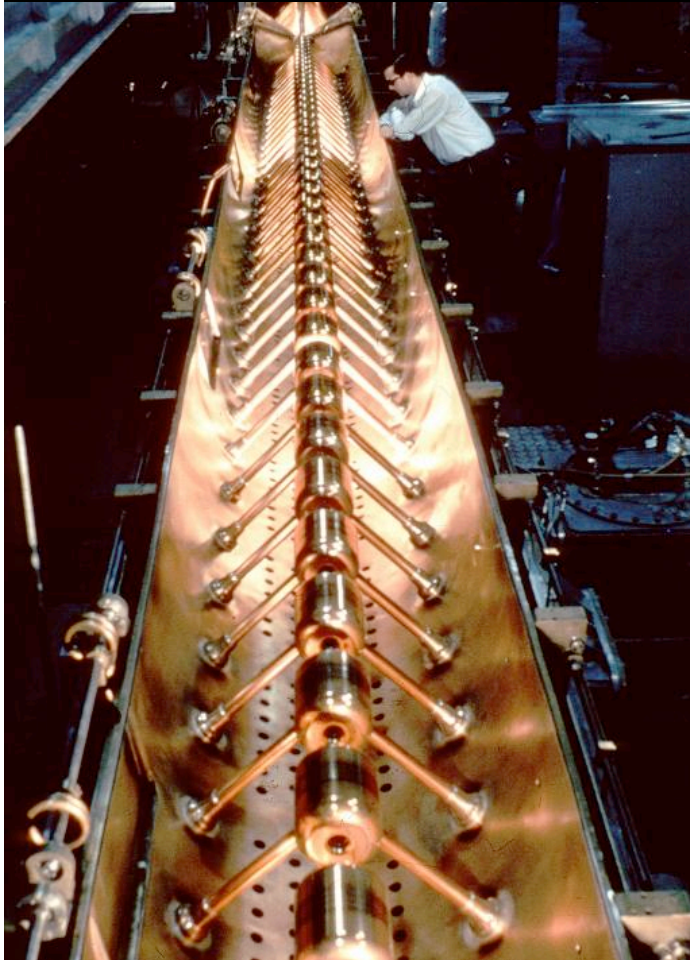

LINAC 2 (CERN)

© CERN Geneva



Electron Linac

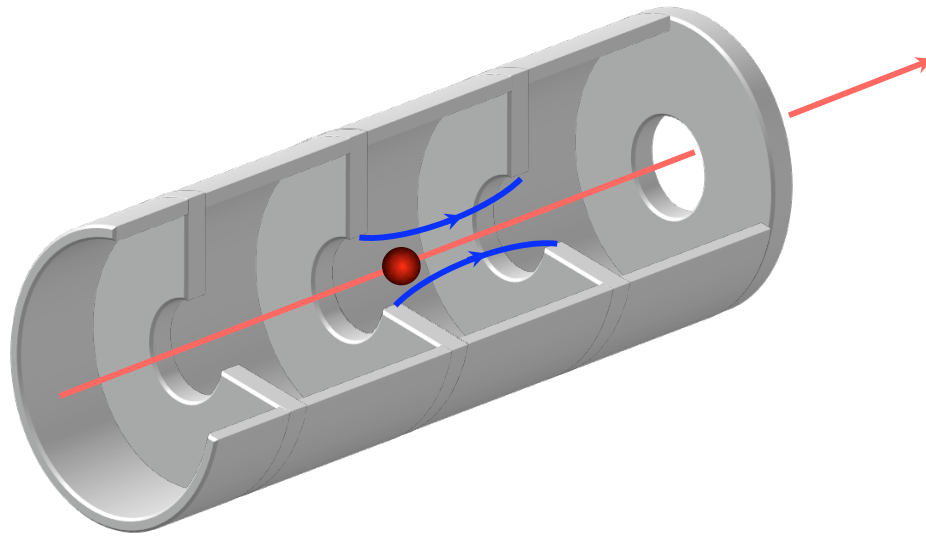

Electrons are light \Rightarrow fast acceleration
 $\Rightarrow \beta \approx 1$ already at an energy of a few MeV



Uniform disk-loaded waveguide, travelling wave
 (up to 50 GeV, $f \sim 3$ GHz - S-band)

$$E(z, t) = E_0 e^{i(\omega t - kz)} \quad \text{Electric field}$$

Wave number $k = \frac{2\pi}{\lambda_{RF}}$

Phase velocity $v_{ph} = \frac{\omega}{k}$

Group velocity $v_g = \frac{d\omega}{dk}$

Synchronism condition \Rightarrow

$$v_{el} \approx c = \frac{\omega}{k} = v_{ph}$$

Electron linacs & structures

LEP Injector Linac (LIL)



© CERN Geneva

CLIC Accelerating Structures (30 GHz & 11 GHz)

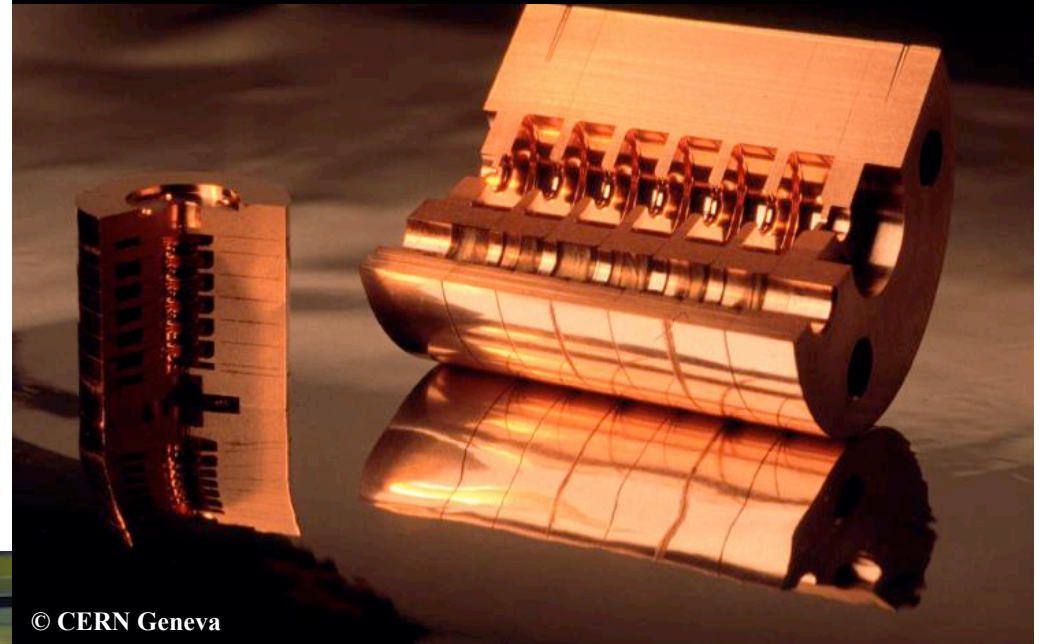

© CERN Geneva



LIL accelerating structure with quadrupoles

© CERN Geneva

Used for protons, ions

Cyclotron

$B = \text{constant}$
 $\omega_{RF} = \text{constant}$

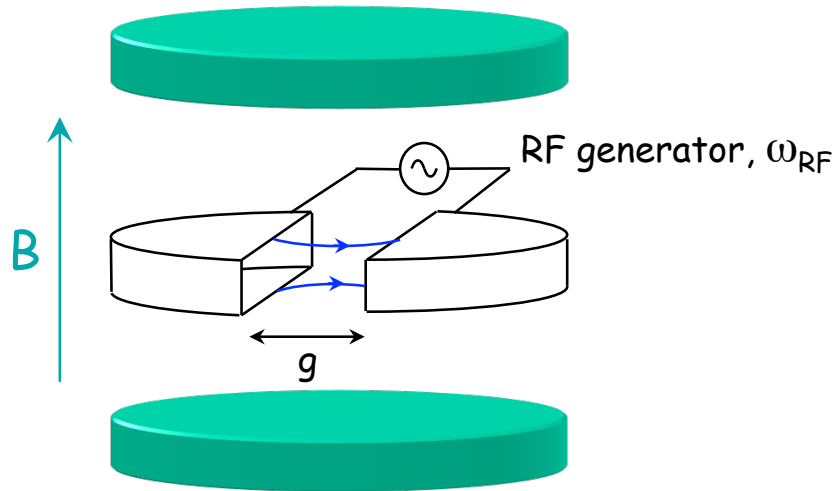

Synchronism condition

$$\omega_s = \omega_{RF}$$

$$2\pi \rho = v_s T_{RF}$$

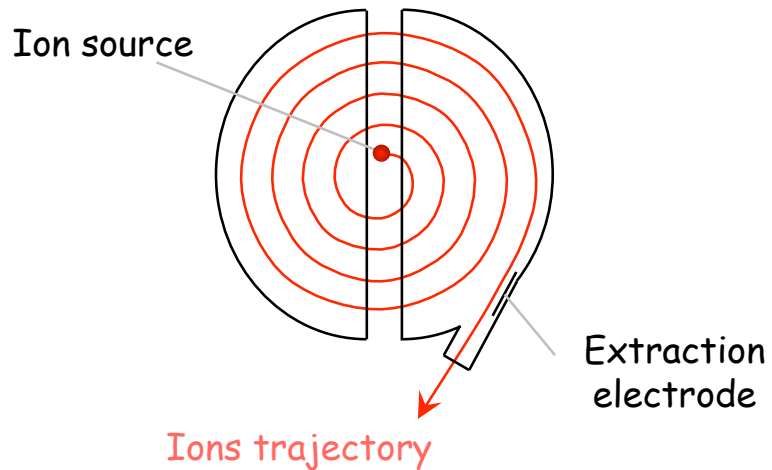

Cyclotron frequency $\omega = \frac{q B}{m_0 \gamma}$

1. γ increases with the energy
 \Rightarrow no exact synchronism
2. if $v \ll c \Rightarrow \gamma \approx 1$



TRIUMF 520 MeV cyclotron

University of British Columbia - Canada

Cyclotron (H^- accelerated, protons extracted)

Synchrocyclotron

Same as cyclotron, except a modulation of ω_{RF}

B = constant

$\gamma \omega_{RF}$ = constant

ω_{RF} decreases with time

The condition:

$$\omega_s(t) = \omega_{RF}(t) = \frac{q B}{m_0 \gamma(t)}$$

Allows to go beyond the non-relativistic energies

Synchrotron

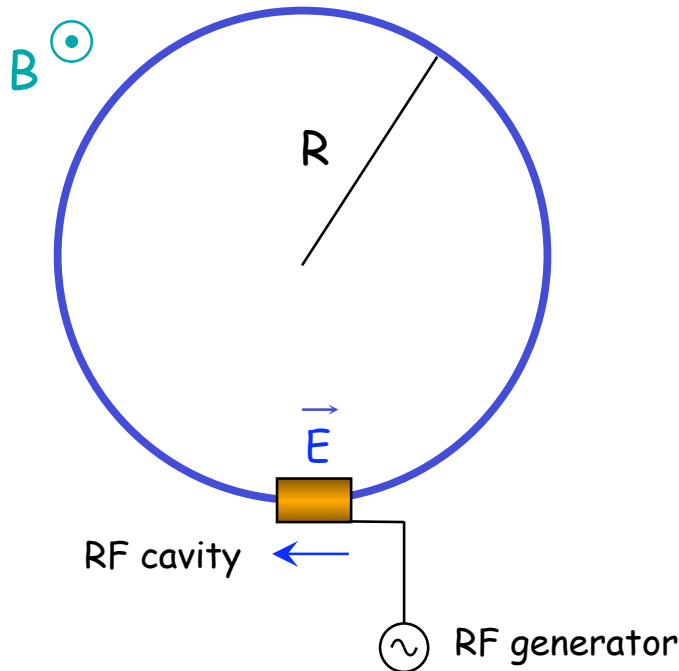

Synchronism condition

$$T_s = h T_{RF}$$

$$\frac{2\pi R}{v_s} = h T_{RF}$$

h integer,
harmonic number

1. ω_{RF} and ω increase with energy
2. To keep particles on the closed orbit, B should increase with time

Synchrotron

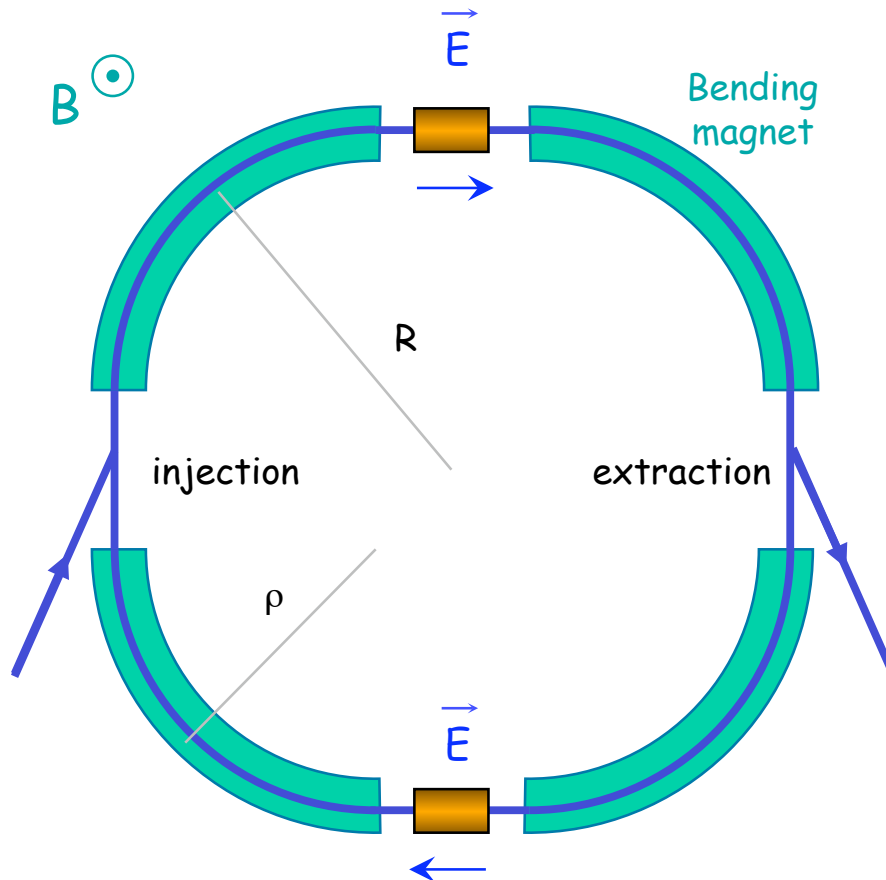

- In reality, the orbit in a synchrotron is not a circle, straight sections are added for RF cavities, injection and extraction, etc..
- Usually the beam is pre-accelerated in a linac (or a smaller synchrotron) before injection
- The bending radius ρ does not coincide to the machine radius $R = L/2\pi$

**LEAR (CERN)
Low Energy Antiproton Ring**



**EPA (CERN)
Electron Positron Accumulator**

© CERN Geneva

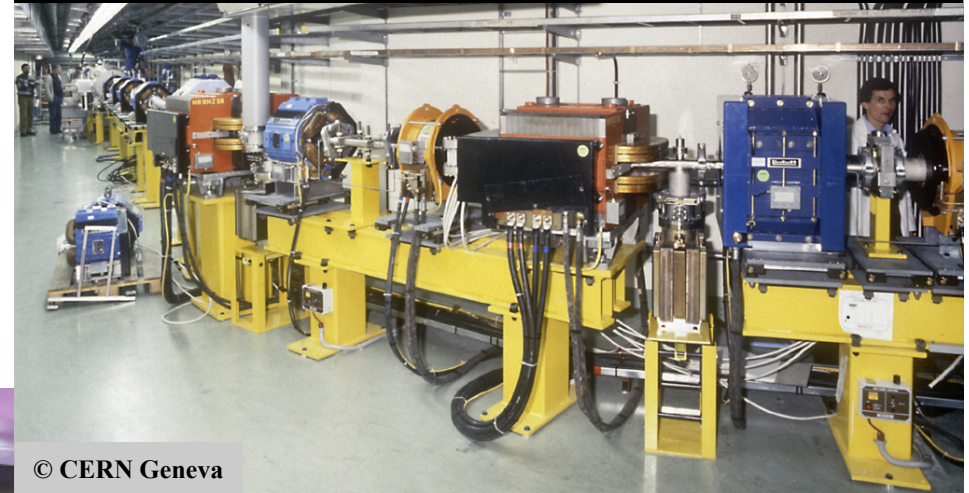

Examples of different proton
and electron synchrotrons at
CERN

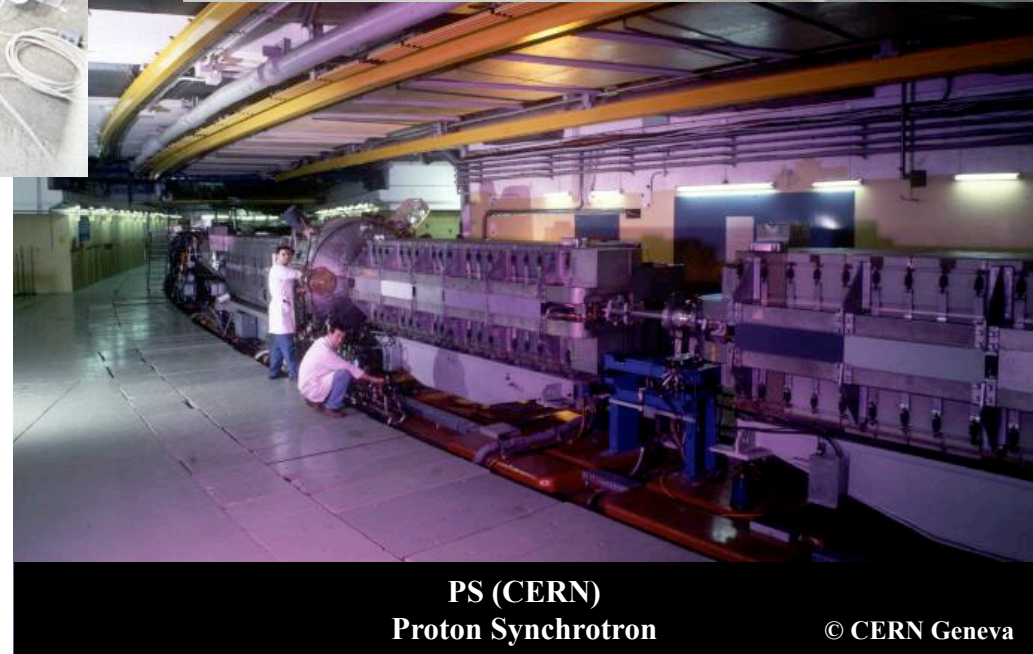

Parameters for circular accelerators

The basic principles, for the common circular accelerators, are based on the two relations:

1. The **Lorentz equation**: the orbit radius can be expressed as:

$$R = \frac{\gamma v m_0}{eB}$$

2. The **synchronicity condition**: The revolution frequency can be expressed as:

$$f = \frac{eB}{2\pi \gamma m_0}$$

According to the parameter we want to keep constant or let vary, one has different acceleration principles. They are summarized in the table below:

Machine	Energy (γ)	Velocity	Field	Orbit	Frequency
Cyclotron	~ 1	var.	const.	$\sim v$	const.
Synchrocyclotron	var.	var.	B(r)	$\sim p$	B(r)/ $\gamma(t)$
Proton/Ion synchrotron	var.	var.	$\sim p$	R	$\sim v$
Electron synchrotron	var.	const.	$\sim p$	R	const.

Transit time factor

RF acceleration in a gap g

$$E(s, r, t) = E_1(s, r) \cdot E_2(t)$$

Simplified model



$$E_1(s, r) = \frac{V_{RF}}{g} = \text{const.}$$

$$E_2(t) = \sin(\omega_{RF} t + \phi_0)$$

At $t = 0, s = 0$ and $v \neq 0$, parallel to the electric field

Energy gain:

$$\Delta E = e \int_{-g/2}^{g/2} E(s, r, t) ds$$



$$\Delta E = e V_{RF} T_a \sin \phi_0$$

where

$$T_a = \frac{\sin \frac{\omega_{RF} g}{2v}}{\frac{\omega_{RF} g}{2v}}$$

T_a is called transit time factor

- $T_a < 1$

- $T_a \rightarrow 1$ if $g \rightarrow 0$

Transit time factor II

In the general case, the **transit time factor** is given by:

$$T_a = \frac{\int_{-\infty}^{+\infty} E_1(s, r) \cos\left(\omega_{RF} \frac{s}{v}\right) ds}{\int_{-\infty}^{+\infty} E_1(s, r) ds}$$

It is the ratio of the peak energy gained by a particle with velocity v to the peak energy gained by a particle with infinite velocity.

Main RF parameters

I. Voltage, phase, frequency

In order to accelerate particles, longitudinal fields must be generated in the direction of the desired acceleration

$$E(s, t) = E_1(s) \cdot E_2(t) \qquad E_2(t) = E_0 \sin \left[\int_{t_0}^t \omega_{RF} dt + \phi_0 \right]$$

$$\omega_{RF} = 2\pi f_{RF} \qquad \Delta E = e V_{RF} T_a \sin \phi_0$$

Such electric fields are generated in RF cavities characterized by the voltage amplitude, the frequency and the phase

II. Harmonic number

$$T_{rev} = h T_{RF} \implies f_{RF} = h f_{rev}$$

f_{rev} = revolution frequency
 f_{RF} = frequency of the RF
 h = harmonic number

harmonic number in different machines:

AA	EPA	PS	SPS
1	8	20	4620

Dispersion

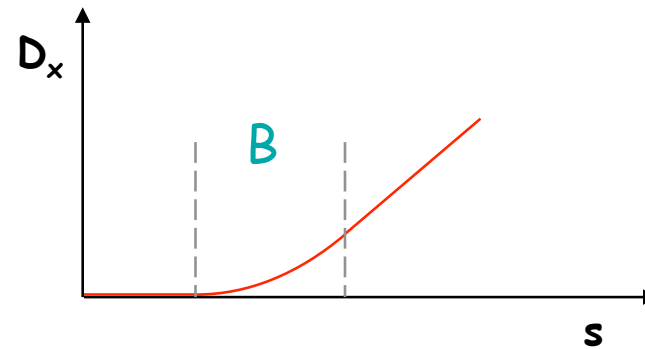
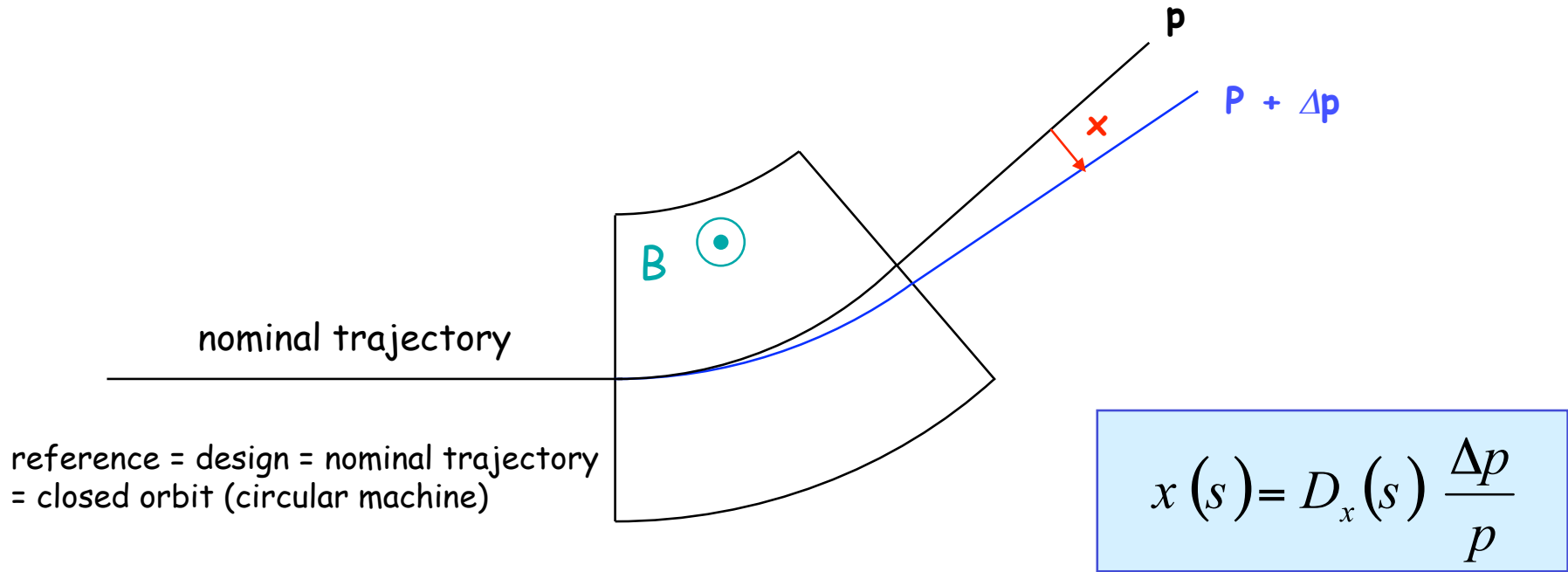

Momentum compaction factor in a transport system

In a particle transport system, a **nominal trajectory** is defined for the **nominal momentum p** .

For a particle with a momentum $p + \Delta p$ the trajectory length can be different from the length L of the nominal trajectory.

The momentum compaction factor is defined by the ratio:

$$\alpha_p = \frac{dL/L}{dp/p}$$

Therefore, for small momentum deviation, to first order it is:

$$\frac{\Delta L}{L} = \alpha_p \frac{\Delta p}{p}$$

Example: constant magnetic field

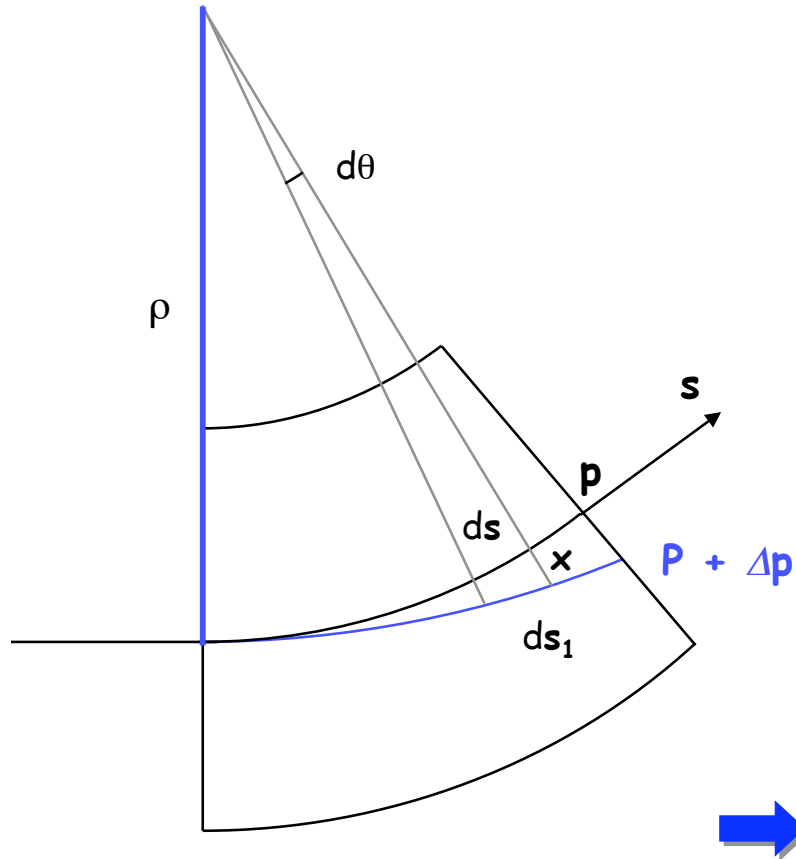

$$ds = \rho d\theta$$

$$ds_1 = (\rho + x)d\theta$$

$$\frac{ds_1 - ds}{ds} = \frac{(\rho + x)d\theta - \rho d\theta}{\rho d\theta} = \frac{x}{\rho} = \frac{D_x}{\rho} \frac{dp}{p}$$

By definition of dispersion D_x

$$\alpha_p = \frac{1}{L} \int_0^L \frac{D_x(s)}{\rho(s)} ds$$

To first order, only the bending magnets contribute to a change of the trajectory length ($r = \infty$ in the straight sections)

Longitudinal phase space

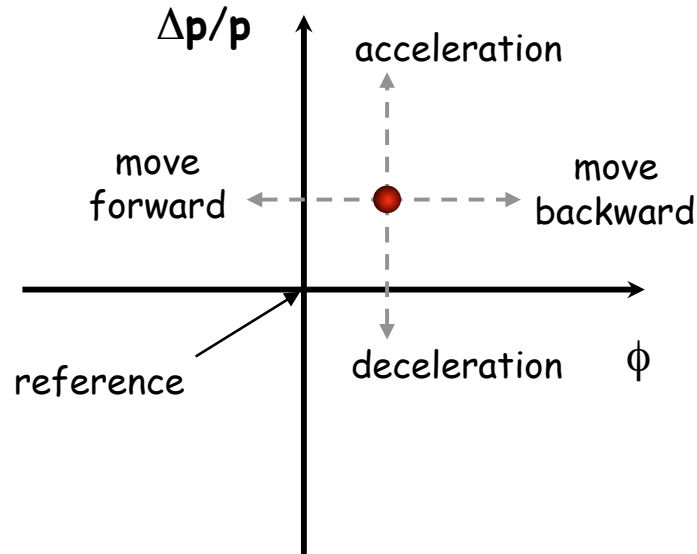

The particle trajectory in the phase space ($\Delta p/p, \phi$) describes its longitudinal motion.

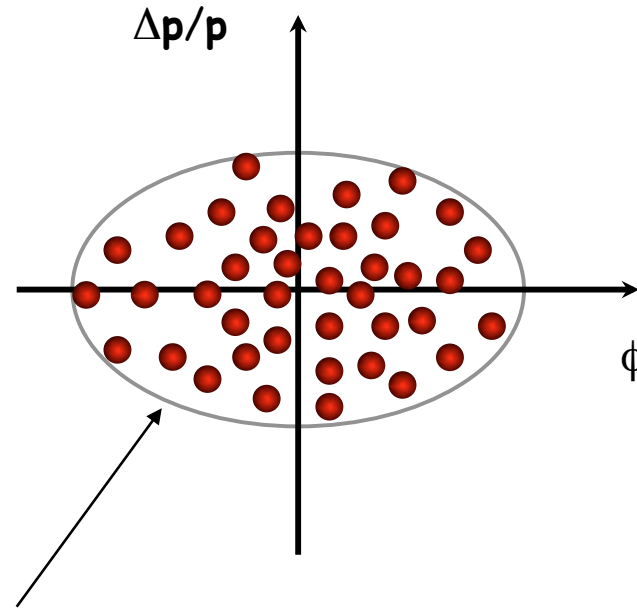

Emittance: phase space area including all the particles

NB: if the emittance contour correspond to a possible orbit in phase space, its shape does not change with time (matched beam)

Bunch compressor

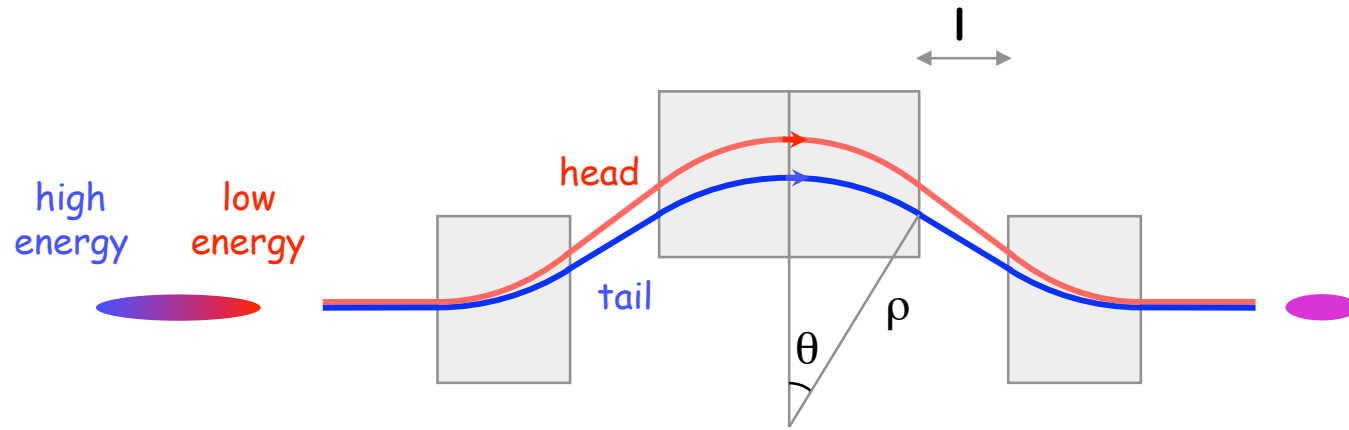

$$\Delta L = \left[4 \rho \frac{\tan \theta - \theta}{\sin \theta} + 2l \tan^2 \theta \right] \frac{\Delta p}{p}$$

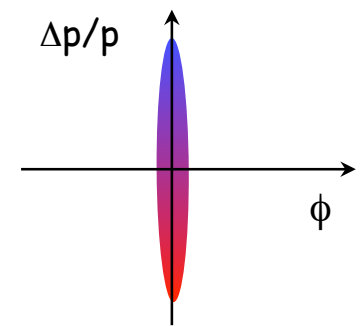
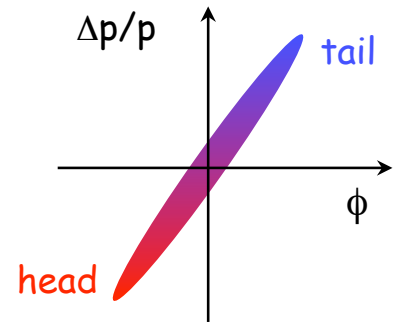

Bunch compression

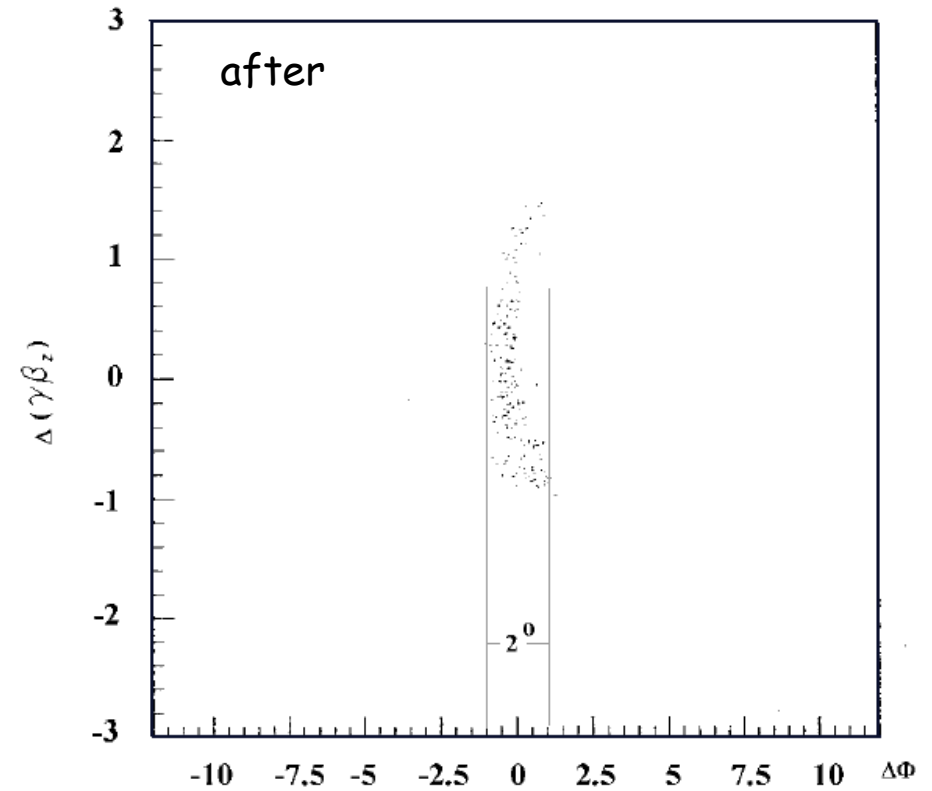
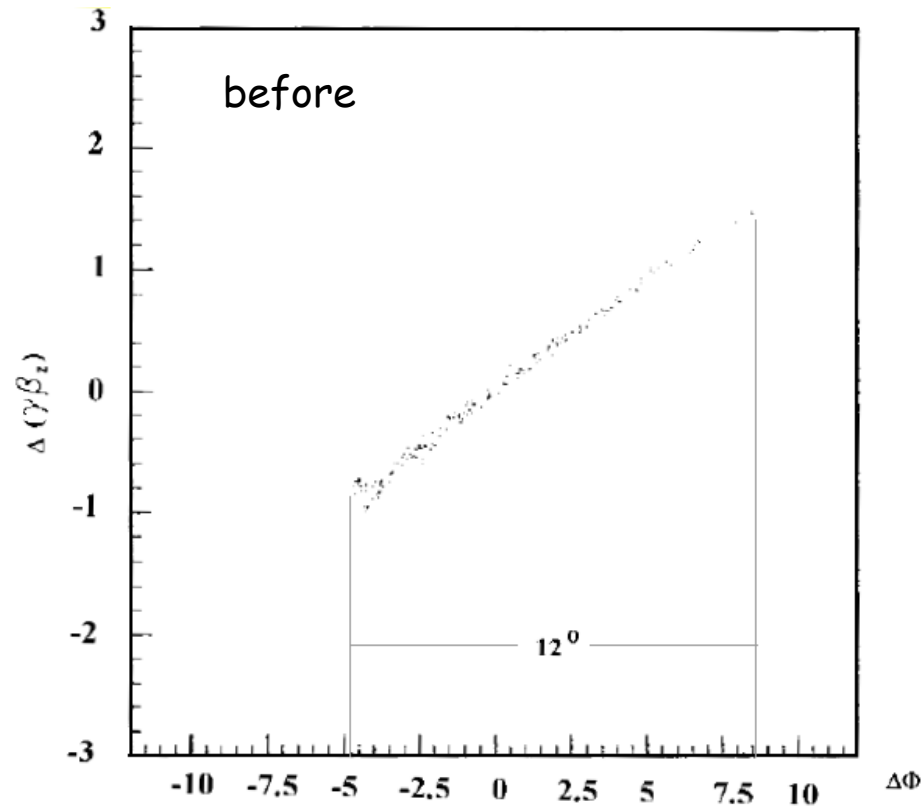

Longitudinal phase space evolution for a bunch compressor (PARMELA code simulations)

Momentum compaction in a ring

In a circular accelerator, a **nominal closed orbit** is defined for the **nominal momentum p** .

For a particle with a momentum deviation Δp produces an orbit length variation ΔC with:

For $B = \text{const.}$

$$\frac{\Delta C}{C} = \alpha_p \frac{\Delta p}{p}$$

$$C = 2\pi R$$

/
\

circumference
(average) radius of the closed orbit

The momentum compaction factor is defined by the ratio:

$$\alpha_p = \frac{dC/C}{dp/p} = \frac{dR/R}{dp/p}$$

and

$$\alpha_p = \frac{1}{C} \int_C \frac{D_x(s)}{\rho(s)} ds$$

N.B.: in most circular machines, α_p is positive \Rightarrow higher momentum means longer circumference

Momentum compaction as a function of energy

$$E = \frac{pc}{\beta} \quad \rightarrow \quad \frac{dE}{E} = \beta^2 \frac{dp}{p}$$

$$\alpha_p = \beta^2 \frac{E}{R} \frac{dR}{dE}$$

Momentum compaction as a function of magnetic field

Definition of average magnetic field

$$\langle B \rangle = \frac{1}{2\pi R} \int_C B_f ds = \frac{1}{2\pi R} \left(\int_{\text{straights}} B_f ds + \int_{\text{magnets}} B_f ds \right)$$

\downarrow $= 0$ \downarrow $2\pi \rho B_f$

$$\langle B \rangle = \frac{B_f \rho}{R}$$

$$B_f \rho = \frac{p}{e}$$

$$\langle B \rangle R = \frac{p}{e}$$

$$\frac{d \langle B \rangle}{\langle B \rangle} = \frac{dB_f}{B_f} + \frac{d\rho}{\rho} - \frac{dR}{R}$$

$$\frac{d \langle B \rangle}{\langle B \rangle} + \frac{dR}{R} = \frac{dp}{p}$$

For $B_f = \text{const.}$

$$\alpha_p = 1 - \frac{d \langle B \rangle}{\langle B \rangle} / \frac{dp}{p}$$

Transition energy

Proton (ion) circular machine with α_p positive

1. Momentum larger than the nominal ($p + \Delta p$) \Rightarrow longer orbit ($C + \Delta C$)
2. Momentum larger than the nominal ($p + \Delta p$) \Rightarrow higher velocity ($v + \Delta v$)

What happens to the revolution frequency $f = v/C$?

- At low energy, v increases faster than C with momentum
- At high energy $v \cong c$ and remains almost constant



There is an energy for which the velocity variation is compensated by the trajectory variation \Rightarrow transition energy

Below transition: higher energy \Rightarrow higher revolution frequency
Above transition: higher energy \Rightarrow lower revolution frequency

Transition energy - quantitative approach

We define a parameter η (revolution frequency spread per unit of momentum spread):

$$\eta = \frac{\frac{df}{f}}{\frac{dp}{p}} = \frac{\frac{d\omega}{\omega}}{\frac{dp}{p}}$$

$$f = \frac{v}{C} \quad \rightarrow \quad \frac{df}{f} = \frac{d\beta}{\beta} - \frac{dC}{C}$$

from $p = \frac{m_0 c \beta}{\sqrt{1-\beta^2}}$ \rightarrow $\frac{d\beta}{\beta} = \frac{1}{\gamma^2} \frac{dp}{p}$ definition of momentum compaction factor: $\frac{dC}{C} = \alpha_p \frac{dp}{p}$

$$\frac{df}{f} = \left(\frac{1}{\gamma^2} - \alpha_p \right) \frac{dp}{p}$$

Transition energy - quantitative approach

$$\eta = \frac{1}{\gamma^2} - \alpha_p$$

The transition energy is the energy that corresponds to $\eta = 0$
 (α_p is fixed, and γ variable)



$$\gamma_{tr} = \sqrt{\frac{1}{\alpha_p}}$$

The parameter η can also be written as

$$\eta = \frac{1}{\gamma^2} - \frac{1}{\gamma_{tr}^2}$$

- At low energy $\eta > 0$
- At high energy $\eta < 0$

N.B.: for electrons, $\gamma \gg \gamma_{tr} \Rightarrow \eta < 0$
 for linacs $\alpha_p = 0 \Rightarrow \eta > 0$

LESSON III

Equations related to synchrotrons

Synchronous particle

Synchrotron oscillations

Principle of phase stability

Equations related to synchrotrons

$$\frac{dp}{p} = \gamma_{tr}^2 \frac{dR}{R} + \frac{dB}{B}$$

$$\frac{dp}{p} = \gamma^2 \frac{df}{f} + \gamma^2 \frac{dR}{R}$$

$$\frac{dB}{B} = \gamma_{tr}^2 \frac{df}{f} + \left[1 - \left(\frac{\gamma_{tr}}{\gamma} \right)^2 \right] \frac{dp}{p}$$

$$\frac{dB}{B} = \gamma^2 \frac{df}{f} + \left(\gamma^2 - \gamma_{tr}^2 \right) \frac{dR}{R}$$

p [MeV/c] momentum

R [m] orbit radius

B [T] magnetic field

f [Hz] rev. frequency

γ_{tr} transition energy

I - Constant radius

$$dR = 0$$

Beam maintained on the same orbit when energy varies

$$\frac{dp}{p} = \frac{dB}{B}$$

$$\frac{dp}{p} = \gamma^2 \frac{df}{f}$$

If p increases



B increases
 f increases

II - Constant energy

$$dp = 0$$

$$V_{RF} = 0$$

Beam debunches

$$\frac{dp}{p} = 0 = \gamma_{tr}^2 \frac{dR}{R} + \frac{dB}{B}$$

$$\frac{dp}{p} = 0 = \gamma^2 \frac{df}{f} + \gamma^2 \frac{dR}{R}$$

If **B** increases



R decreases
f increases

III - Magnetic flat-top

$$dB = 0$$

Beam bunched with constant magnetic field

$$\frac{dp}{p} = \gamma_{tr}^2 \frac{dR}{R}$$

$$\frac{dB}{B} = 0 = \gamma_{tr}^2 \frac{df}{f} + \left[1 - \left(\frac{\gamma_{tr}}{\gamma} \right)^2 \right] \frac{dp}{p}$$

$$\frac{dB}{B} = 0 = \gamma^2 \frac{df}{f} + (\gamma^2 - \gamma_{tr}^2) \frac{dR}{R}$$

If **p** increases



R increases

f increase $\gamma < \gamma_{tr}$

decreases $\gamma > \gamma_{tr}$

IV - Constant frequency

$$df = 0$$

Beam driven by an external oscillator

$$\frac{dp}{p} = \gamma^2 \frac{dR}{R}$$

$$\frac{dB}{B} = \left[1 - \left(\frac{\gamma_{tr}}{\gamma} \right)^2 \right] \frac{dp}{p}$$

$$\frac{dB}{B} = (\gamma^2 - \gamma_{tr}^2) \frac{dR}{R}$$

If p increases

 R increases
 B decreases $\gamma < \gamma_{tr}$
 increase $\gamma > \gamma_{tr}$

Four conditions - resume

Beam	Parameter	Variations
Debunched	$\Delta p = 0$	$B \uparrow, R \downarrow, f \uparrow$
Fixed orbit	$\Delta R = 0$	$B \uparrow, p \uparrow, f \uparrow$
Magnetic flat-top	$\Delta B = 0$	$p \uparrow, R \uparrow, f \uparrow (\eta > 0)$ $f \downarrow (\eta < 0)$
External oscillator	$\Delta f = 0$	$B \uparrow, p \downarrow, R \downarrow (\eta > 0)$ $p \uparrow, R \uparrow (\eta < 0)$

p momentum

R orbit radius

B magnetic field

f frequency

Simple case (no accel.): $B = \text{const.}$ $\gamma < \gamma_{tr}$

Synchronous particle

Synchronous particle: particle that sees always the same phase (at each turn) in the RF cavity



$$\omega = \frac{e B}{\gamma m_0} = \frac{\omega_{RF}}{h}$$

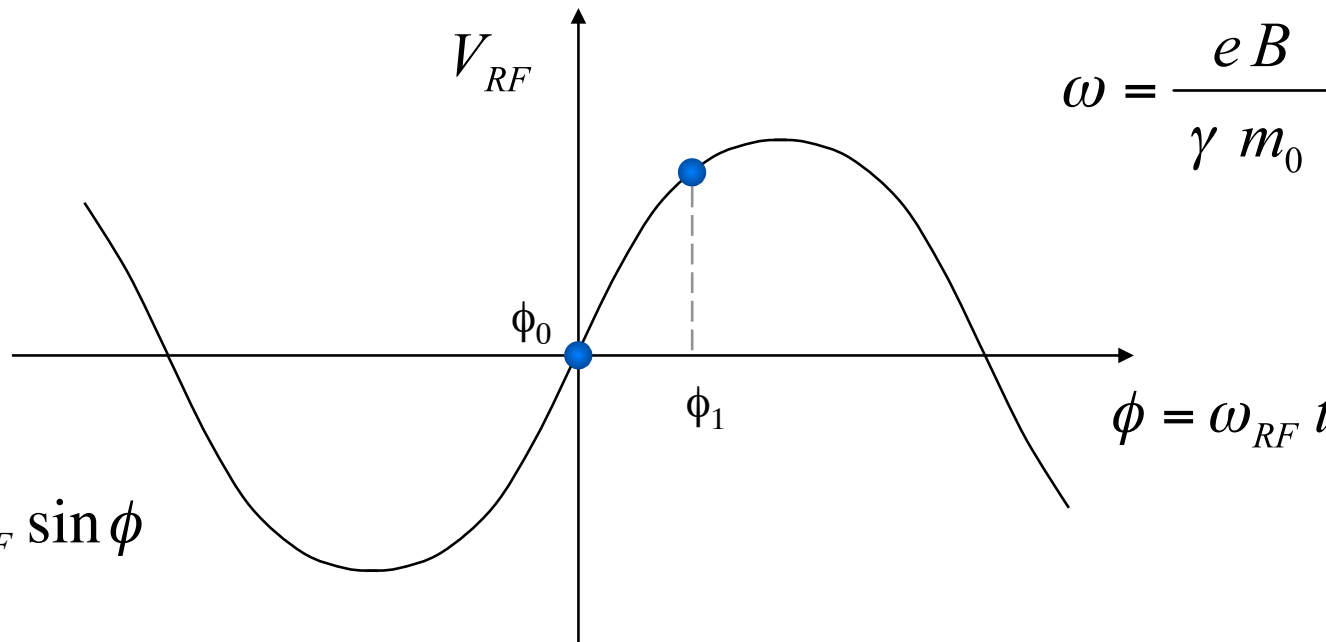

$$\Delta E = e \hat{V}_{RF} \sin \phi$$

In order to keep the **resonant condition**, the particle must keep a **constant energy**
 The phase of the synchronous particle must therefore be $\phi_0 = 0$ (circular machines convention)
 Let's see what happens for a particle with the same energy and a different phase (e.g., ϕ_1)

Synchrotron oscillations

ϕ_1

- The particle is accelerated
- Below transition, an increase in energy means an increase in revolution frequency
- The particle arrives earlier - tends toward ϕ_0

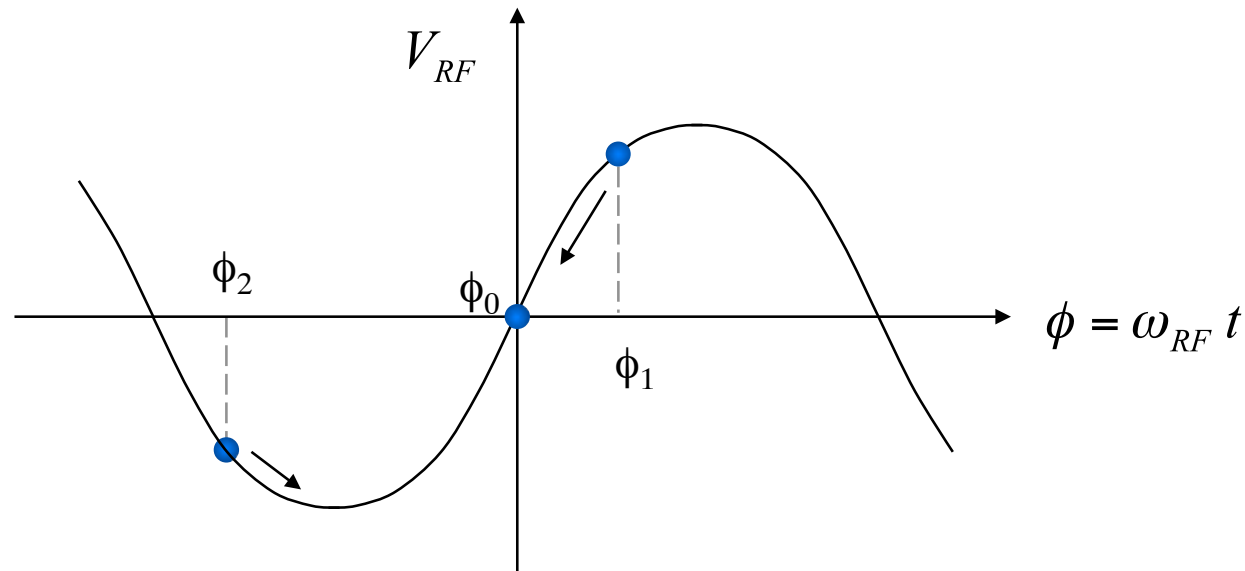

ϕ_2

- The particle is decelerated
- decrease in energy - decrease in revolution frequency
- The particle arrives later - tends toward ϕ_0

Synchrotron oscillations

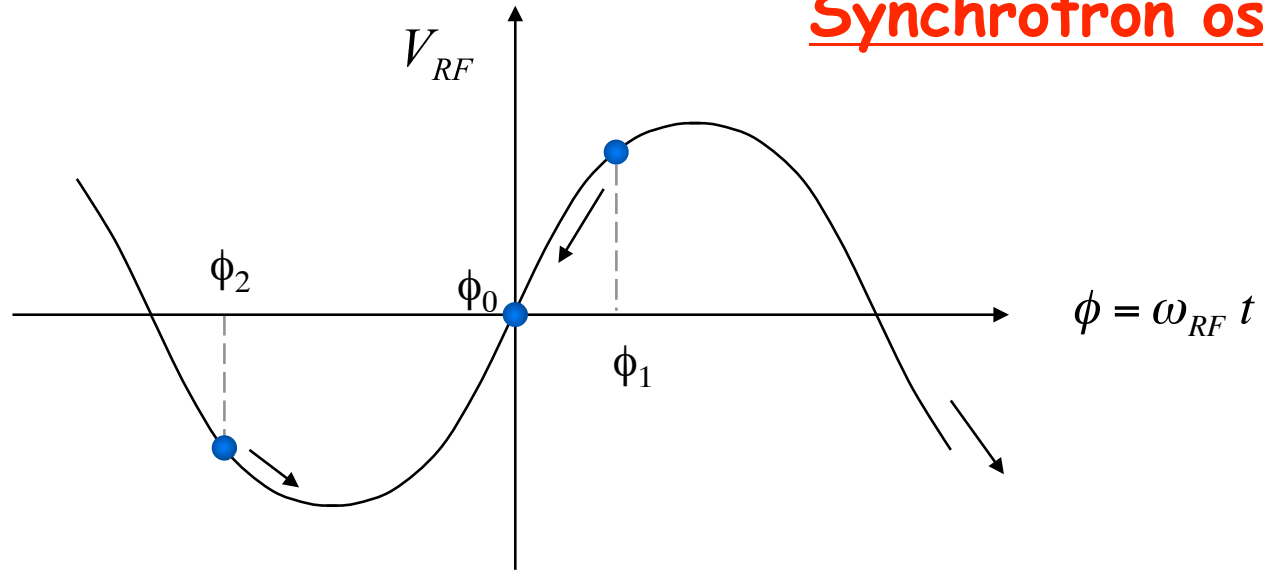

Phase space picture

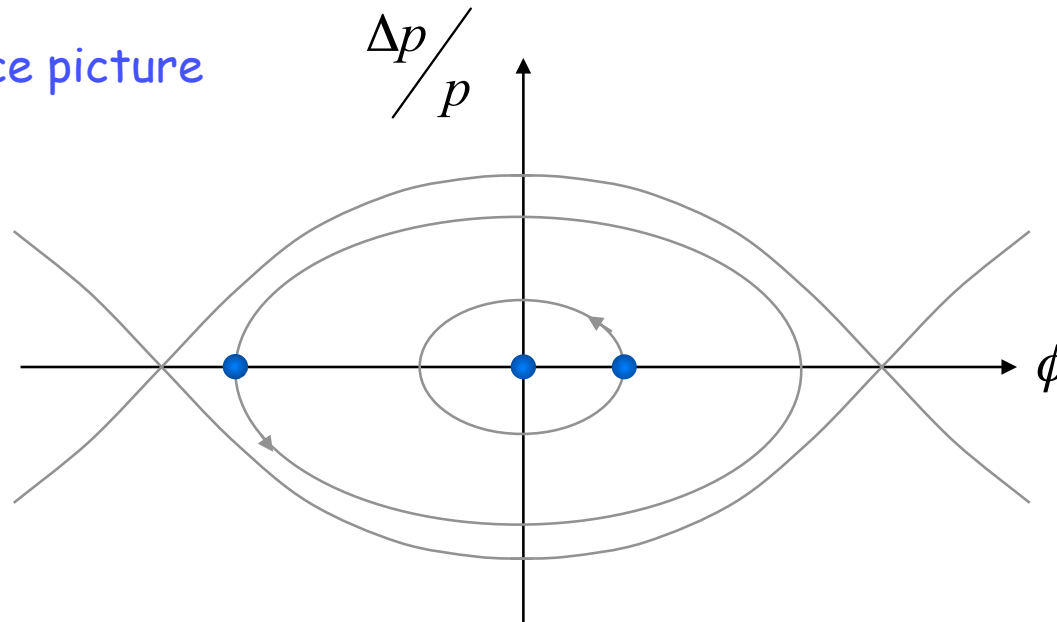

Synchronous particle

Case with acceleration **B increasing** $\gamma < \gamma_{tr}$

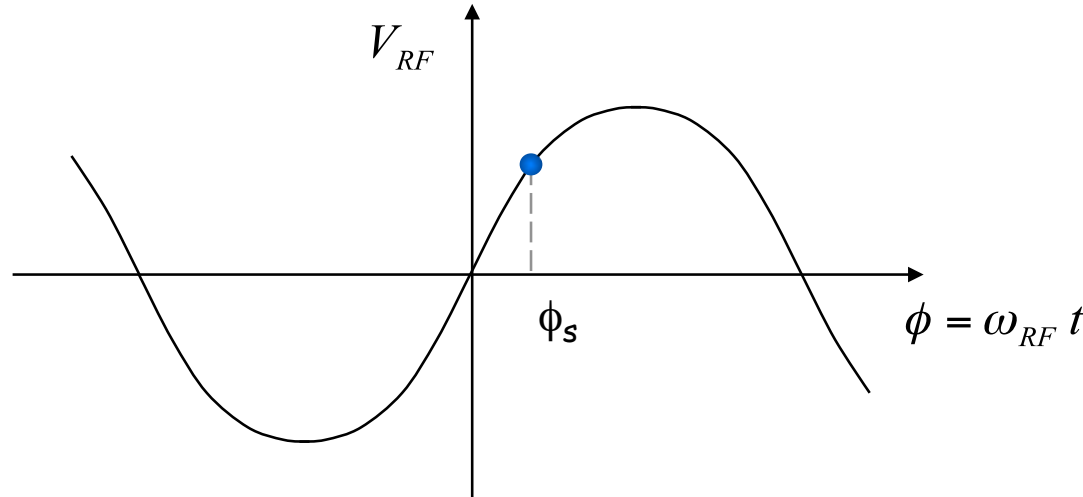

$$\Delta E = e \hat{V}_{RF} \sin \phi$$

The phase of the synchronous particle is now $\phi_s > 0$ (circular machines convention)

The synchronous particle accelerates, and the magnetic field is increased accordingly to keep the **constant radius R**

$$R = \frac{\gamma v m_0}{eB}$$

The RF frequency is increased as well in order to keep the **resonant condition**

$$\omega = \frac{eB}{\gamma m_0} = \frac{\omega_{RF}}{h}$$

Phase stability

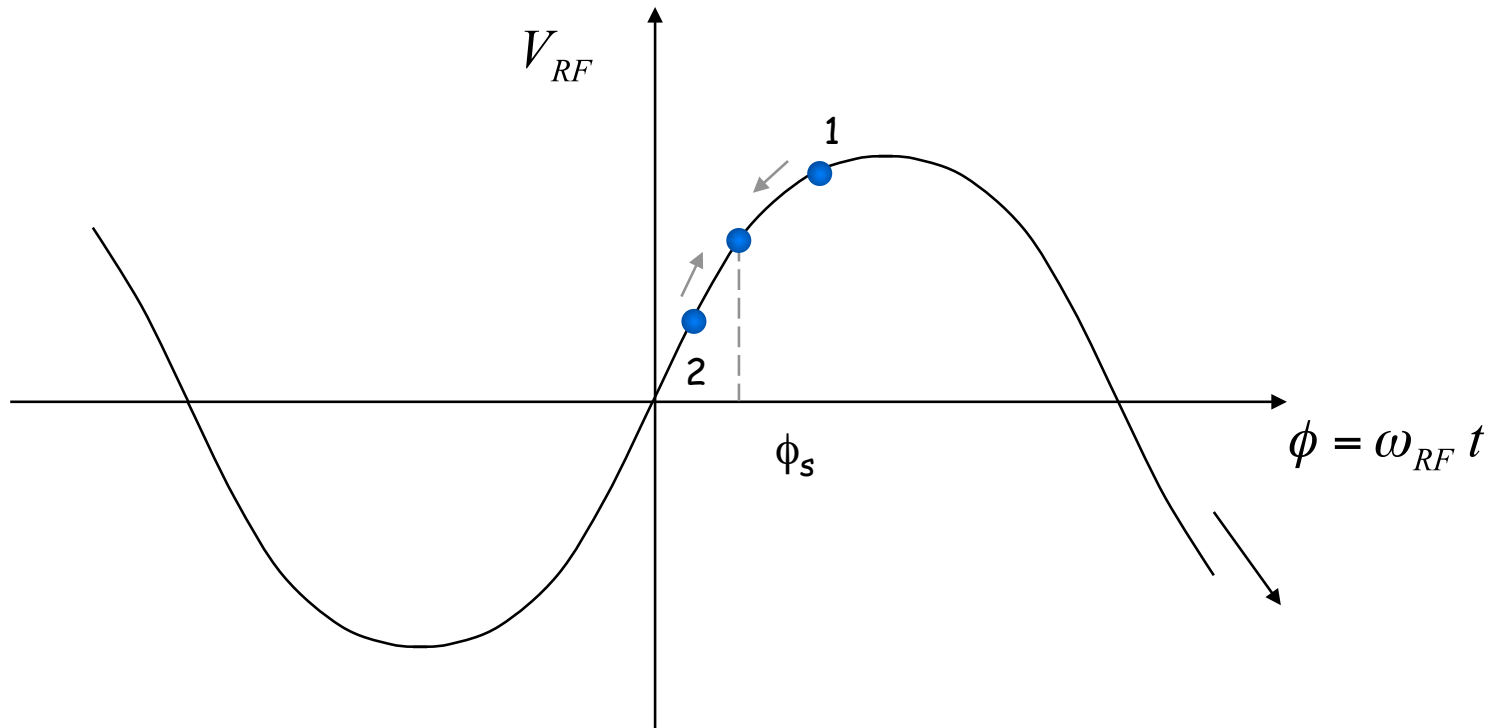

Phase stability

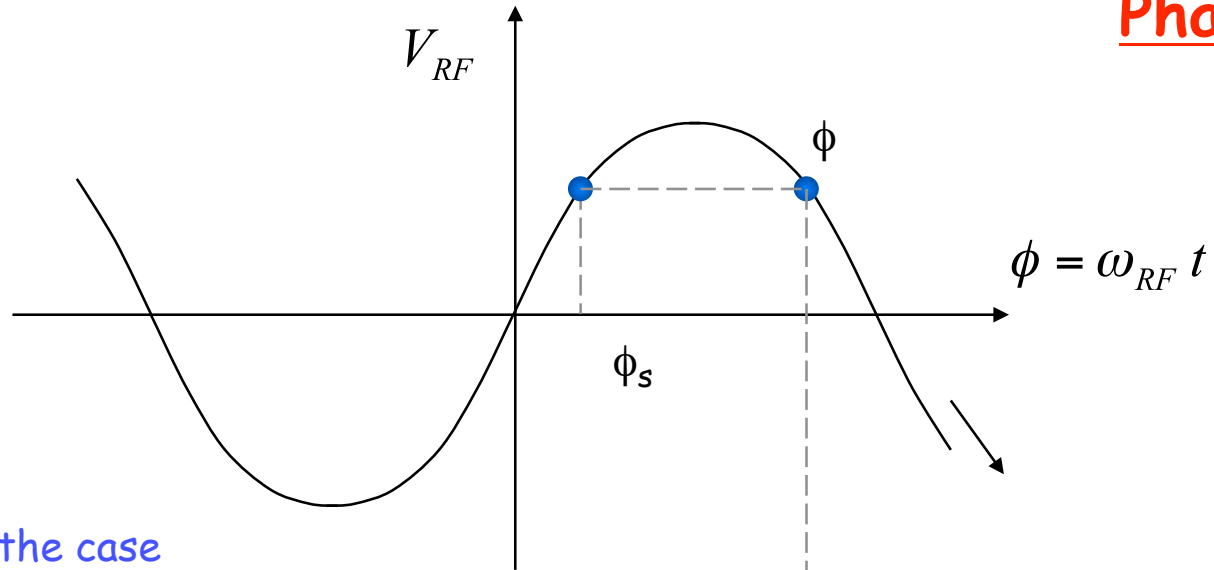

The symmetry of the case with $B = \text{const.}$ is lost

$$\phi_s < \phi < \pi - \phi_s$$

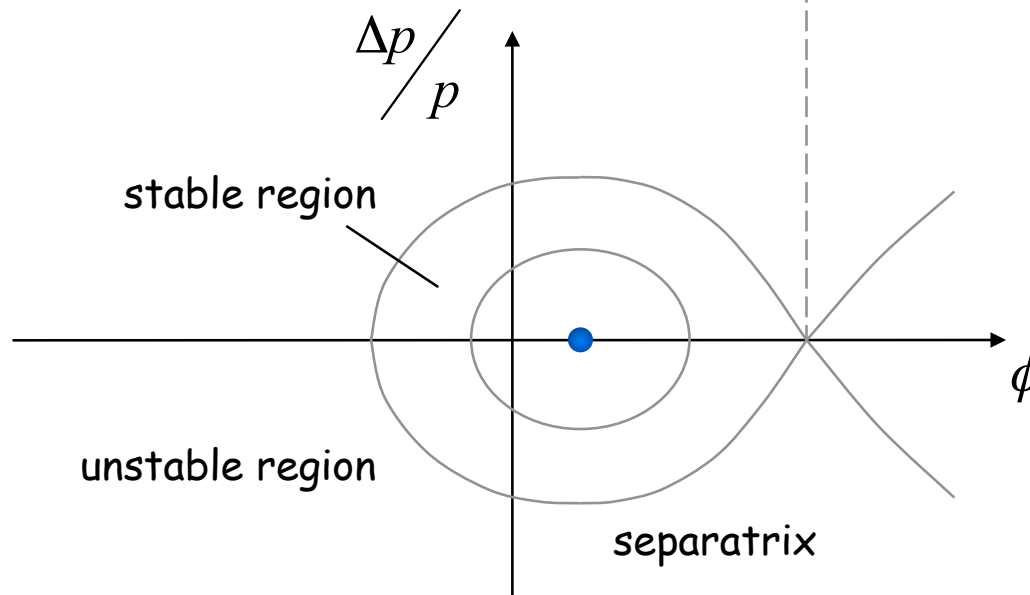

LESSON IV

RF acceleration for synchronous particle

RF acceleration for non-synchronous particle

Small amplitude oscillations

Large amplitude oscillations - the RF bucket

RF acceleration for synchronous particle - energy gain

Let's assume a synchronous particle with a given $\phi_s > 0$

We want to calculate its rate of acceleration, and the related rate of increase of B , f .

$$p = e B \rho$$

Want to keep $\rho = \text{const}$

$$\rightarrow \frac{dp}{dt} = e \rho \frac{dB}{dt} = e \rho \dot{B}$$

Over one turn:
$$(\Delta p)_{turn} = e \rho \dot{B} T_{rev} = e \rho \dot{B} \frac{2\pi R}{\beta c}$$

We know that (relativistic equations) :
$$\Delta p = \frac{\Delta E}{\beta c}$$



$$(\Delta E)_{turn} = e \rho \dot{B} 2\pi R$$

RF acceleration for synchronous particle - phase

$$(\Delta E)_{turn} = e \rho \dot{B} 2\pi R \quad \text{On the other hand, for the synchronous particle:} \quad (\Delta E)_{turn} = e \hat{V}_{RF} \sin \phi_s$$

$$e \rho \dot{B} 2\pi R = e \hat{V}_{RF} \sin \phi_s$$

Therefore:

1. Knowing ϕ_s , one can calculate the increase rate of the magnetic field needed for a given RF voltage:



$$\dot{B} = \frac{\hat{V}_{RF}}{2\pi \rho R} \sin \phi_s$$

2. Knowing the magnetic field variation and the RF voltage, one can calculate the value of the synchronous phase:

$$\sin \phi_s = 2\pi \rho R \frac{\dot{B}}{\hat{V}_{RF}} \quad \rightarrow \quad \phi_s = \arcsin \left(2\pi \rho R \frac{\dot{B}}{\hat{V}_{RF}} \right)$$

RF acceleration for synchronous particle - frequency

$$\omega_{RF} = h\omega_s = h \frac{e}{m} \langle B \rangle \quad \left(v = \frac{e}{m} B\rho \right)$$

$$\omega_{RF} = h \frac{e}{m} \frac{\rho}{R} B$$

From relativistic equations:

$$\omega_{RF} = \frac{hc}{R} \sqrt{\frac{B^2}{B^2 + (E_0/ec\rho)^2}}$$

Let

$$B_0 \equiv \frac{E_0}{ec\rho}$$



$$f_{RF} = \frac{hc}{2\pi R} \left(\frac{B}{B_0} \right) \frac{1}{\sqrt{1 + (B/B_0)^2}}$$

Example: PS

At the CERN Proton Synchrotron machine, one has:

$$R = 100 \text{ m}$$

$$\dot{B} = 2.4 \text{ T/s}$$

100 dipoles with $l_{\text{eff}} = 4.398 \text{ m}$. The harmonic number is 20

Calculate:

1. The energy gain per turn
2. The minimum RF voltage needed
3. The RF frequency when $B = 1.23 \text{ T}$ (at extraction)

RF acceleration for non synchronous particle

Parameter definition (subscript "s" stands for synchronous particle):

$$f = f_s + \Delta f \quad \text{revolution frequency}$$

$$\phi = \phi_s + \Delta\phi \quad \text{RF phase}$$

$$p = p_s + \Delta p \quad \text{Momentum}$$

$$E = E_s + \Delta E \quad \text{Energy}$$

$$\theta = \theta_s + \Delta\theta \quad \text{Azimuth angle}$$

$$ds = R d\theta$$

$$\theta(t) = \int_{t_0}^t \omega(\tau) d\tau$$

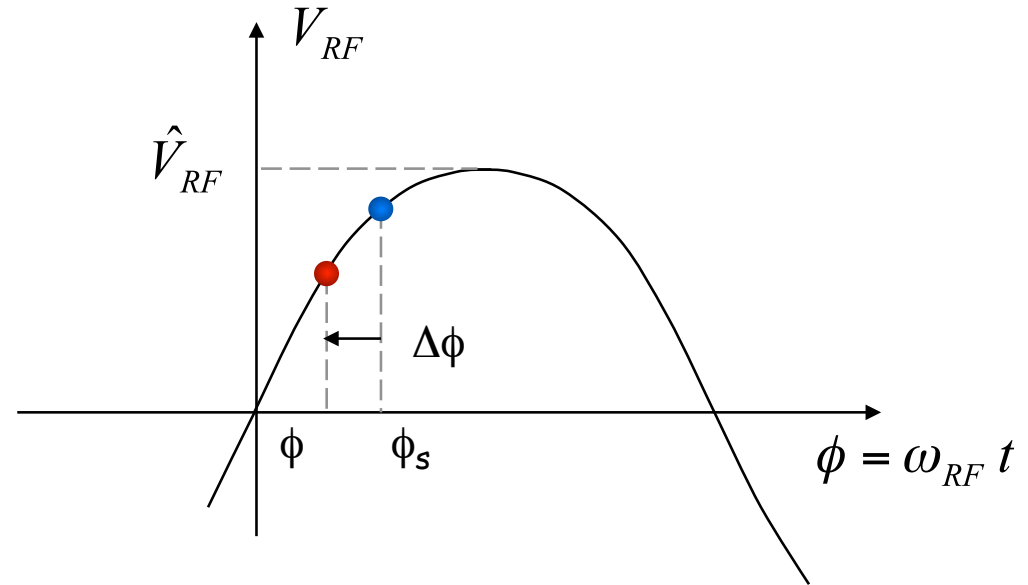
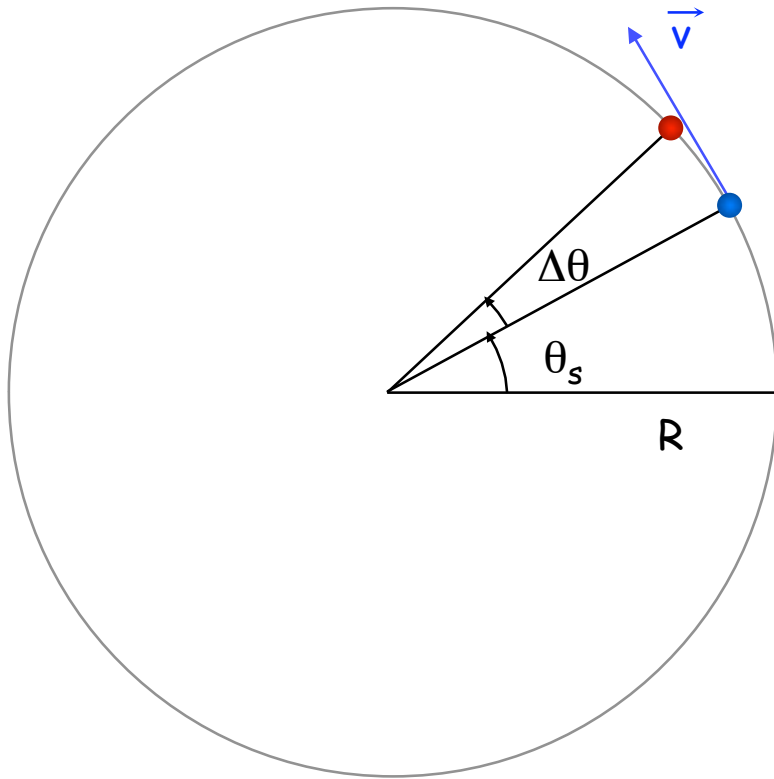

$$\Delta\theta > 0 \Rightarrow \Delta\phi < 0$$

Since $f_{RF} = h f_{rev}$



$$\Delta\phi = -h \Delta\theta$$

Over one turn θ varies by 2π
 ϕ varies by $2\pi h$

Parameters versus $\dot{\phi}$

1. Angular frequency

$$\theta(t) = \int_{t_0}^t \omega(\tau) d\tau$$

$$\Delta\omega = \frac{d}{dt}(\Delta\theta)$$

$$= -\frac{1}{h} \frac{d}{dt}(\Delta\phi)$$

$$= -\frac{1}{h} \frac{d}{dt}(\phi - \phi_s)$$

$$\frac{d\phi_s}{dt} = 0 \text{ by definition}$$

$$= -\frac{1}{h} \frac{d\phi}{dt}$$



$$\Delta\omega = -\frac{1}{h} \frac{d\phi}{dt}$$

Parameters versus $\dot{\phi}$

2. Momentum

$$\eta = \frac{\frac{d\omega}{\omega}}{\frac{dp}{p}} = \frac{\frac{\Delta\omega}{\omega}}{\frac{\Delta p}{p}}$$

$$\Delta p = \frac{p_s}{\omega_s} \frac{\Delta\omega}{\eta} = \frac{p_s}{\omega_s \eta} \left(-\frac{1}{h} \frac{d\phi}{dt} \right)$$



$$\Delta p = \frac{-p_s}{\omega_s \eta h} \frac{d\phi}{dt}$$

3. Energy

$$\frac{dE}{dp} = v$$

$$\frac{\Delta E}{\Delta p} = v = \omega R$$



$$\Delta E = -\frac{R p_s}{\eta h} \frac{d\phi}{dt}$$

Derivation of equations of motion

Energy gain after the RF cavity

$$(\Delta E)_{turn} = e \hat{V}_{RF} \sin \phi$$

$$(\Delta p)_{turn} = \frac{e}{\omega R} \hat{V}_{RF} \sin \phi$$

Average increase per time unit

$$\frac{(\Delta p)_{turn}}{T_{rev}} = \frac{e}{2\pi R} \hat{V}_{RF} \sin \phi \quad 2\pi R \dot{p} = e \hat{V}_{RF} \sin \phi \quad \text{valid for any particle !}$$



$$2\pi (R \dot{p} - R_s \dot{p}_s) = e \hat{V}_{RF} (\sin \phi - \sin \phi_s)$$

Derivation of equations of motion

After some development (see J. Le Duff, in Proceedings CAS 1992, CERN 94-01)

$$2\pi \frac{d}{dt} \left(\frac{\Delta E}{\omega_s} \right) = e \hat{V}_{RF} (\sin \phi - \sin \phi_s)$$

An approximated version of the above is

$$\frac{d(\Delta p)}{dt} = \frac{e \hat{V}_{RF}}{2\pi R_s} (\sin \phi - \sin \phi_s)$$

Which, together with the previously found equation

$$\frac{d\phi}{dt} = - \frac{\omega_s \eta h}{p_s} \Delta p$$

Describes the motion of the non-synchronous particle in the longitudinal phase space ($\Delta p, \phi$)

Equations of motion I

$$\begin{cases} \frac{d(\Delta p)}{dt} = A (\sin \phi - \sin \phi_s) \\ \frac{d\phi}{dt} = B \Delta p \end{cases}$$

with $A = \frac{e \hat{V}_{RF}}{2\pi R_s}$

$$B = -\frac{\eta h \beta_s c}{p_s R_s}$$

Equations of motion II

1. First approximation - combining the two equations:

$$\frac{d}{dt} \left(\frac{1}{B} \frac{d\phi}{dt} \right) - A (\sin \phi - \sin \phi_s) = 0$$

We assume that **A** and **B** change very slowly compared to the variable $\Delta\phi = \phi - \phi_s$



$$\frac{d^2\phi}{dt^2} + \frac{\Omega_s^2}{\cos \phi_s} (\sin \phi - \sin \phi_s) = 0$$

with $\frac{\Omega_s^2}{\cos \phi_s} = -AB$

We can also define: $\Omega_0^2 = \frac{\Omega_s^2}{\cos \phi_s} = \frac{e \hat{V}_{RF} \eta h c^2}{2\pi R_s^2 E_s}$

2. Second approximation

$$\begin{aligned} \sin \phi &= \sin(\phi_s + \Delta\phi) \\ &= \sin \phi_s \cos \Delta\phi + \cos \phi_s \sin \Delta\phi \end{aligned}$$

$$\Delta\phi \text{ small} \Rightarrow \sin \phi \cong \sin \phi_s + \cos \phi_s \Delta\phi$$

$$\frac{d\phi_s}{dt} = 0 \Rightarrow \frac{d^2\phi}{dt^2} = \frac{d^2}{dt^2}(\phi_s + \Delta\phi) = \frac{d^2\Delta\phi}{dt^2}$$

by definition



$$\frac{d^2\Delta\phi}{dt^2} + \Omega_s^2 \Delta\phi = 0$$

Harmonic oscillator !

Stability condition for ϕ_s

Stability is obtained when the angular frequency of the oscillator, Ω_s^2 is real positive:

$$\Omega_s^2 = \frac{e \hat{V}_{RF} \eta h c^2}{2\pi R_s^2 E_s} \cos \phi_s \Rightarrow \Omega_s^2 > 0 \Leftrightarrow \eta \cos \phi_s > 0$$

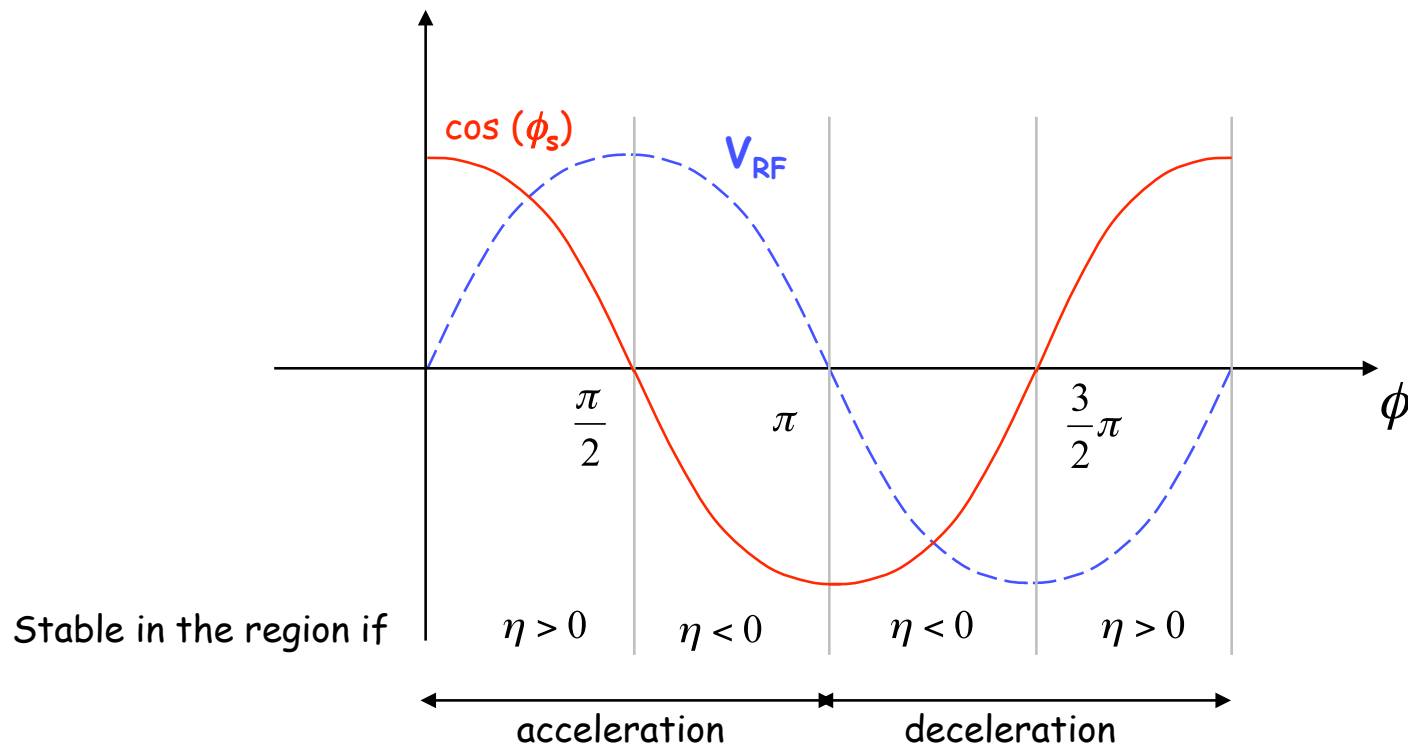

Small amplitude oscillations - orbits

For $\eta \cos \phi_s > 0$ the motion around the synchronous particle is a stable oscillation:

$$\begin{cases} \Delta\phi = \Delta\phi_{\max} \sin(\Omega_s t + \phi_0) \\ \Delta p = \Delta p_{\max} \cos(\Omega_s t + \phi_0) \end{cases}$$

with $\Delta p_{\max} = \frac{\Omega_s}{B} \Delta\phi_{\max}$

Lepton machines

e^+, e^-

$$\beta \cong 1, \quad \gamma \text{ large}, \quad \eta \cong -\alpha_p$$



$$\omega_s \cong \frac{c}{R_s}, \quad p_s \cong \frac{E_s}{c}$$



$$\Omega_s = \frac{c}{R_s} \left\{ -\frac{e \hat{V}_{RF} \alpha_p h}{2\pi E_s} \cos \phi_s \right\}^{1/2}$$

Number of synchrotron oscillations per turn:

$$Q_s = \frac{\Omega_s}{\omega_s} = \left\{ -\frac{e \hat{V}_{RF} \alpha_p h}{2\pi E_s} \cos \phi_s \right\}^{1/2} \quad \text{"synchrotron tune"}$$

N.B: in these machines, the RF frequency does not change

Large amplitude oscillations

$$\ddot{\phi} + \frac{\Omega_s^2}{\cos\phi_s} (\sin\phi - \sin\phi_s) = 0$$



Multiplying by $\dot{\phi}$
and integrating

$$\frac{\dot{\phi}^2}{2} - \frac{\Omega_s^2}{\cos\phi_s} (\cos\phi + \phi \sin\phi_s) = cte$$

Constant of motion

here $\dot{\phi} = 0$

$$\phi = \pi - \phi_s$$

Equation of the separatrix

$$\frac{\dot{\phi}^2}{2} - \frac{\Omega_s^2}{\cos\phi_s} (\cos\phi + \phi \sin\phi_s) = -\frac{\Omega_s^2}{\cos\phi_s} [\cos(\pi - \phi_s) + (\pi - \phi_s) \sin\phi_s]$$

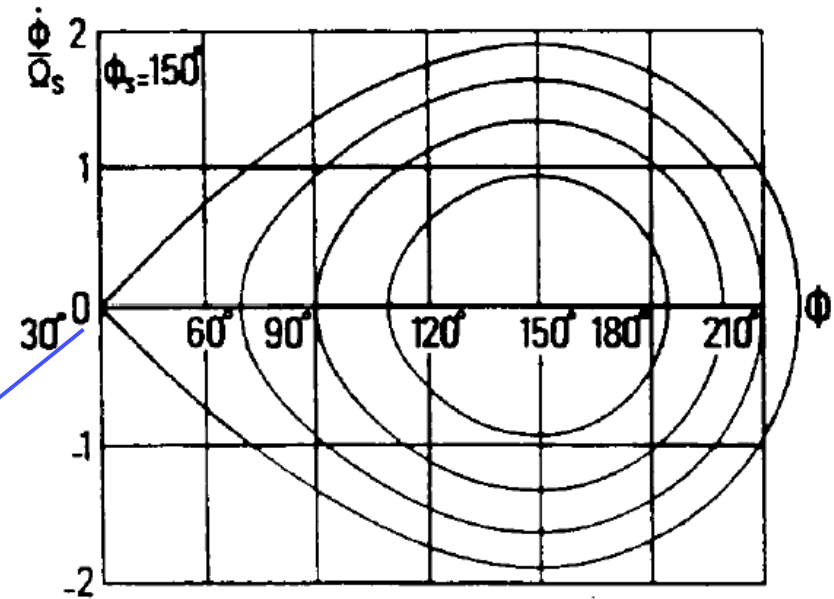

Synchronous phase 150°

"total energy"

$$\frac{\dot{\phi}^2}{2} - \frac{\Omega_s^2}{\cos\phi_s} (\cos\phi + \phi \sin\phi_s) = cte$$

"kinetic energy"

"potential energy U "

$$\frac{d^2\phi}{dt^2} = F(\phi)$$

$$F(\phi) = -\frac{\partial U}{\partial \phi}$$

Energy diagram

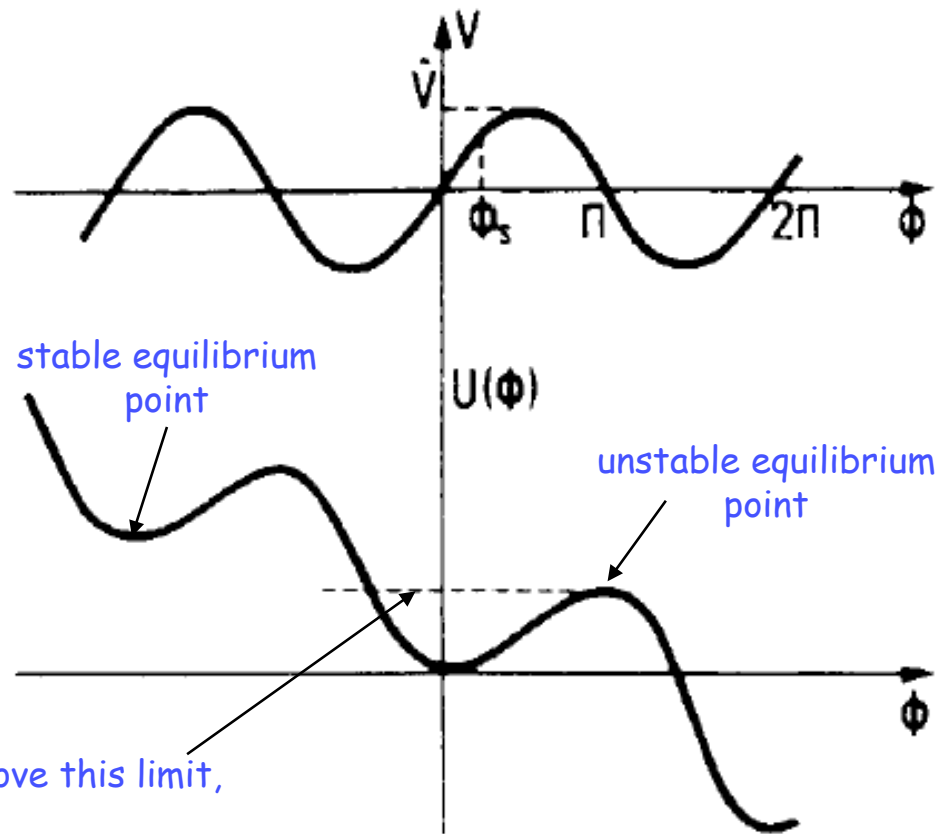

If the total energy is above this limit, the motion is unbounded

Phase space trajectories

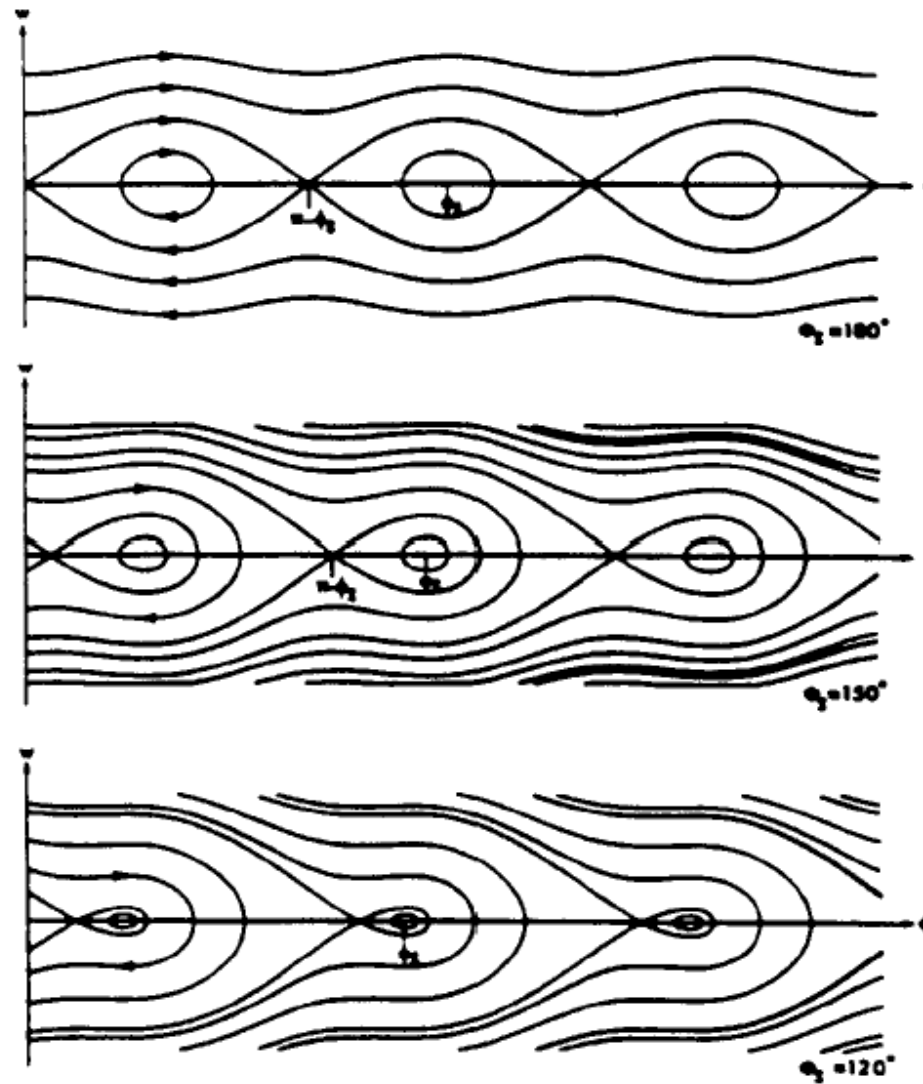

$$\gamma > \gamma_{tr}$$

Phase space trajectories for different synchronous phases

LESSON V

Measurement of the longitudinal bunch profile and Tomography

RF manipulations

The ESME simulation code

Measurement of the longitudinal bunch profile

=> **WALL CURRENT MONITOR** = Device used to measure the instantaneous value of the beam current

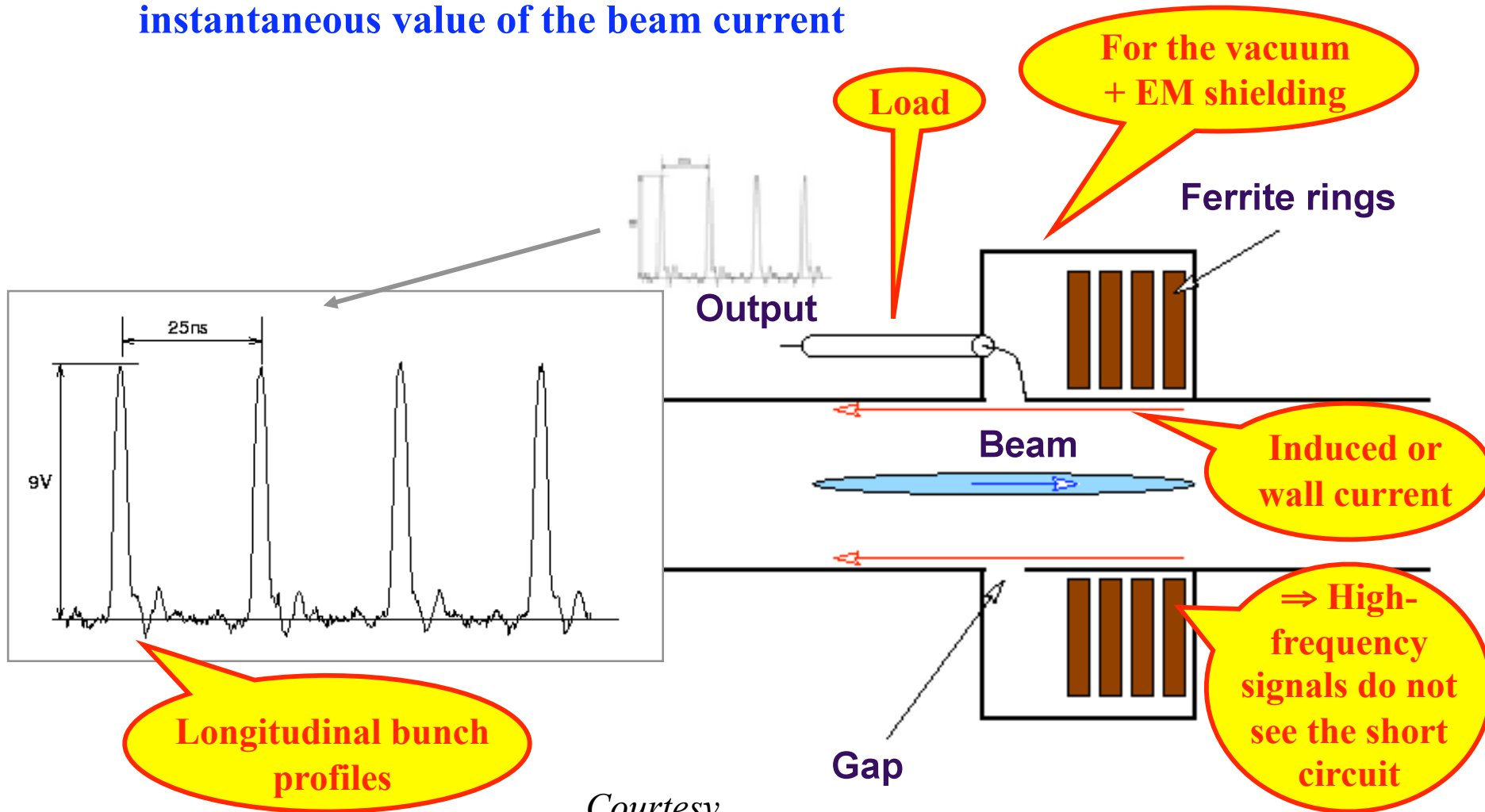

Courtesy
J. Belleman

A Wall Current Monitor

Tomography

TOMOSCOPE (developed by S. Hancock, CERN/BE/RF)

The aim of **TOMOGRAPHY** is to estimate an unknown distribution (here the 2D longitudinal distribution) using only the information in the bunch profiles

Surface = Longitudinal EMITTANCE of the bunch = ϵ_L [eV.s]

Surface = Longitudinal ACCEPTANCE of the bucket

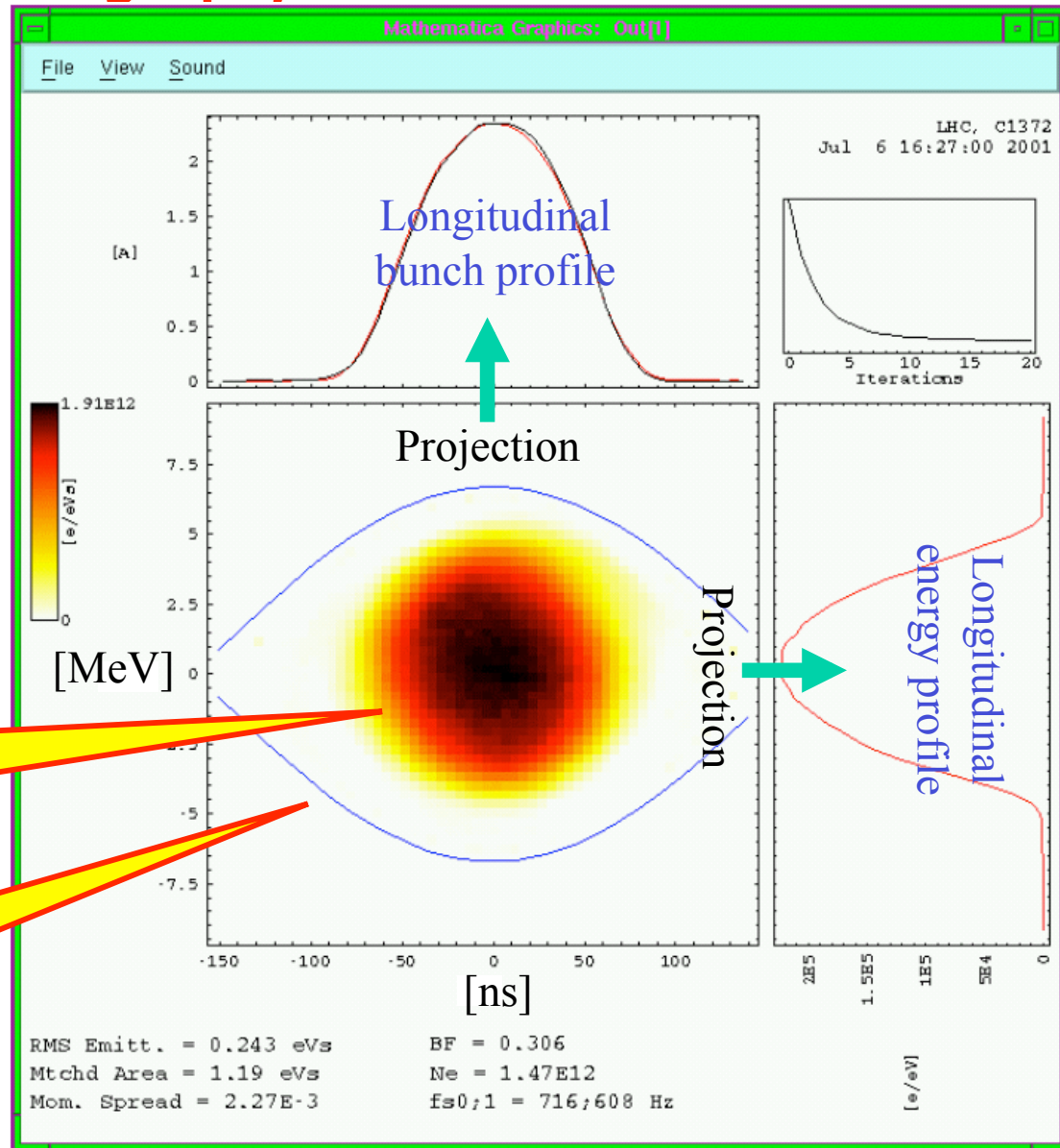

RF manipulations

Double splitting also exists (and also **merging**)
 => See example with ESME)

TRIPLE BUNCH SPLITTING

Courtesy
 R. Garoby

1 trace / 356 revolutions (~ 800 μs)

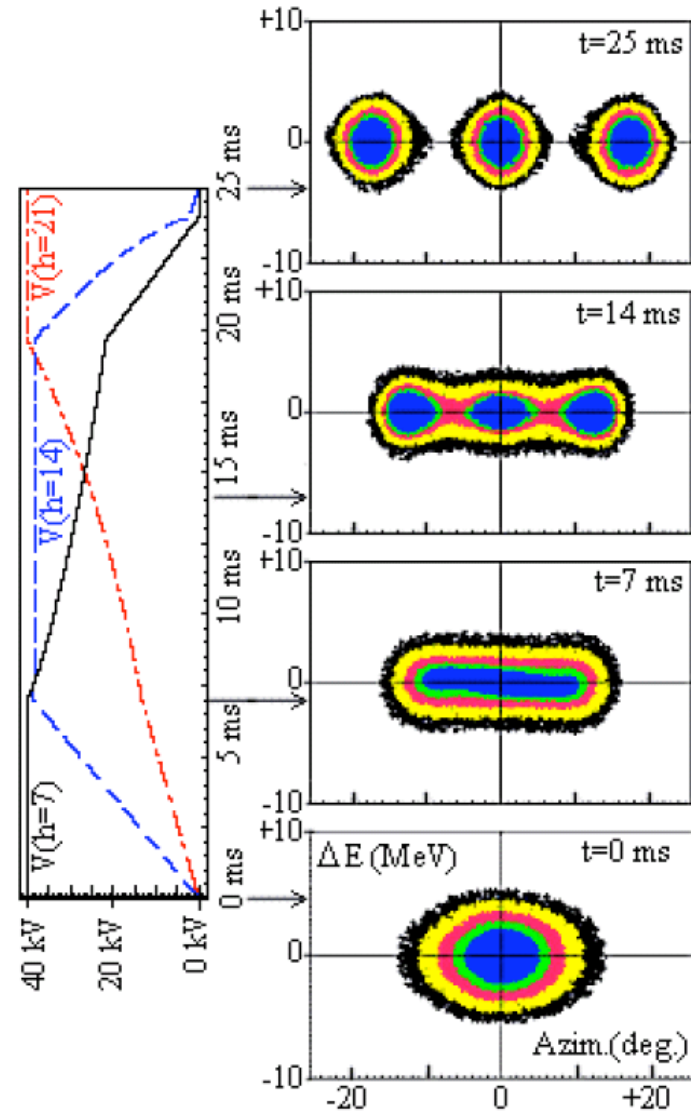
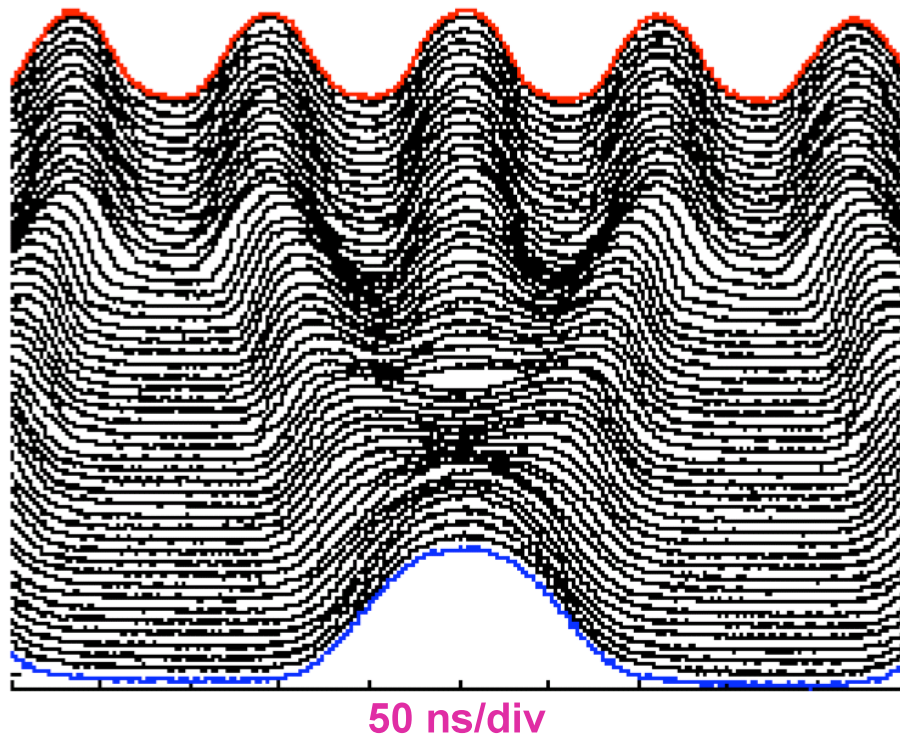

RF manipulations

$\frac{\Delta p}{p_0} = 3.8\%$

BUNCH ROTATION WITH LONGITUDINAL SPACE-CHARGE
TURN 0 0.000E+00 sec

H_0 [MeV]	S_0 [eV s]	E_0 [MeV]	h	v [MV]	ψ [deg]
6.9592E+00	1.2240E+00	2.9383E+03	24	6.923E-02	0.000E+00
ν_s [turn ⁻¹]	β [MeV s ⁻¹]	η			
3.1661E-03	0.0000E+00	-1.0003E-01			
τ [s]	S_0 [eV s]	N			
3.3175E-06	3.1000E-01	20000			

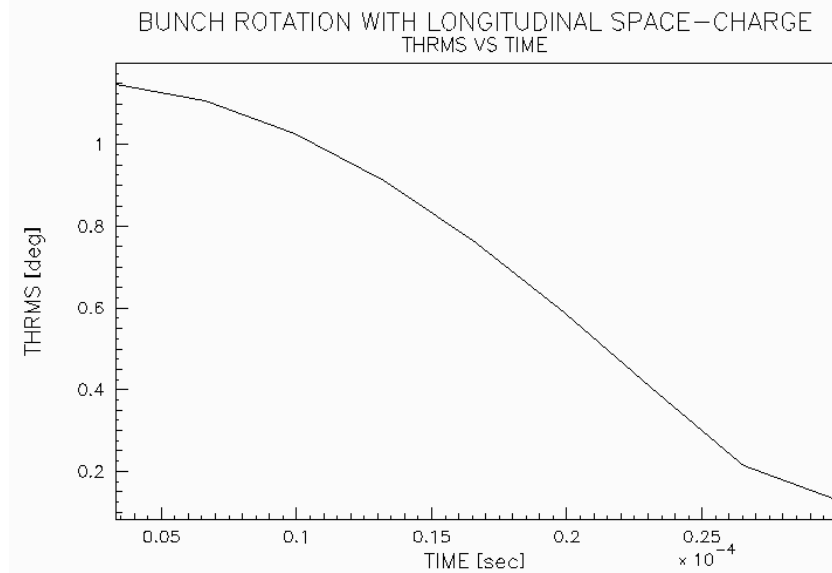
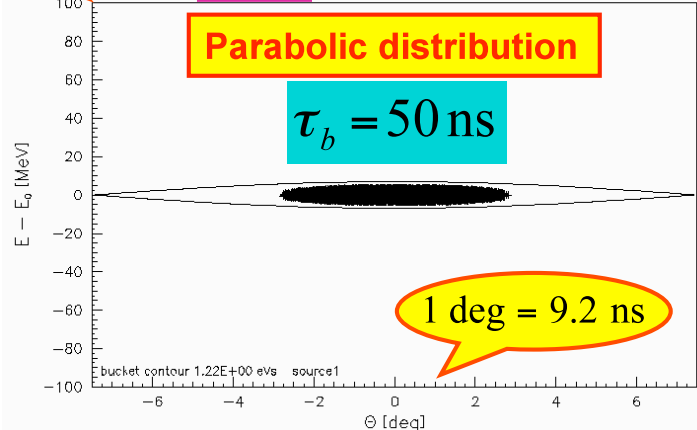

BUNCH ROTATION (with ESME)

BUNCH ROTATION WITH LONGITUDINAL SPACE-CHARGE
TURN 9 2.986E-05 sec

H_0 [MeV]	S_0 [eV s]	E_0 [MeV]	h	v [MV]	ψ [deg]
6.8404E+01	1.1339E+01	2.9383E+03	24	7.000E+00	0.000E+00
ν_s [turn ⁻¹]	β [MeV s ⁻¹]	η			
3.1837E-02	0.0000E+00	-1.0003E-01			
τ [s]	S_0 [eV s]	N			
3.3175E-06	3.1884E-01	20000			

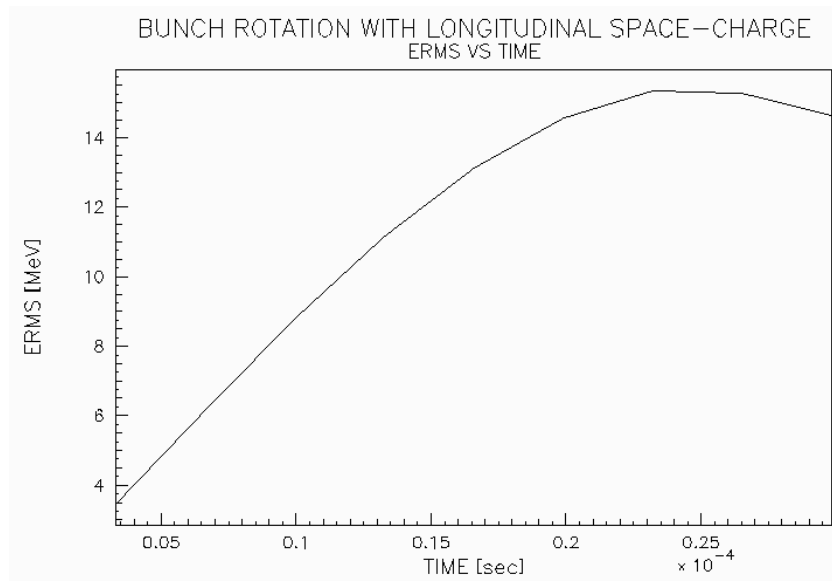
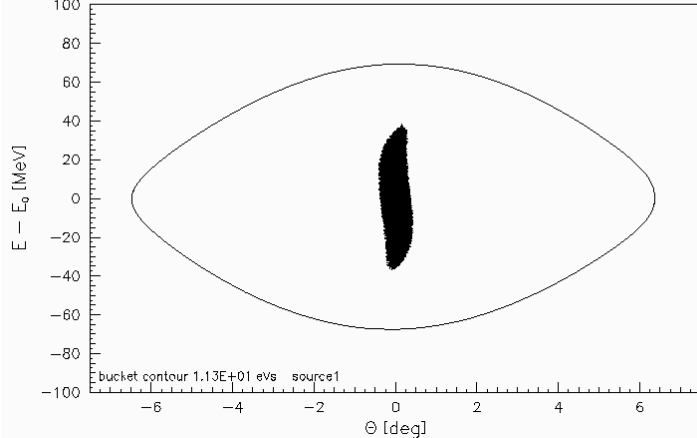

The ESME simulation code

Want to calculate the evolution of a distribution of particles in energy and azimuth as it is acted upon by the Radio Frequency (RF) system of a synchrotron or storage ring? => **Use ESME code**

Several RF systems and many other effects can be included

ESME => It is not an acronym. The name is that of the heroine of J. D. Salinger's short story "To Esme with Love and Squalor"

Code initially developed during the years 1981-82 for the design of the Tevatron I Antiproton Source and first documented for general use in 1984

Homepage = <http://www-ap.fnal.gov/ESME/>

The ESME simulation code

Download and execution of the ESME code in local:

Procedure given in
<http://www-ap.fnal.gov/ESME/>

- 1) We need a recent version of **gcc** / **gfortran** (to compile the fortran program) and the **pgplot library**
- 2) My local executable (many thanks Laurent Deniau, due to my old MAC!) is called **esme** in the folder `/Users/eliasmetral/Documents/CERN/Private_Since_07-12-08/Courses/JUAS/2014/ESME_Tutorial` (Reminder to make this file an executable: **chmod +x esme**)
- 3) To have the labels on the pictures, we need also to install 2 files: **grfont.dat** and **rgb.txt**
- 4) A first example can be taken from the source code downloaded => In the folder `EXAMPLES`, the first input file is called **docdat1.dat** => Put it in the folder where the executable is

The ESME simulation code

**-i = interactive output
(pauses between plots)**

- 5) To run the program with this input file, type: `./esme -i -f docdat1.dat`
=> The program starts to run and ask for Device Specification (? for list) :
=> Typing **? + enter**, one can see the different options for the plots

**-f filename = use
filename for input
instead of standard
input**

```
Device Specification (? for list) :?
PGPLOT v5.2.2 Copyright 1997 California Institute of Technology
Interactive devices:
  /XWINDOW  (X window window@node:display.screen/xw)
  /XSERVE   (A /XWINDOW window that persists for re-use)
Non-interactive file formats:
  /GIF      (Graphics Interchange Format file, landscape orientation)
  /VGIF     (Graphics Interchange Format file, portrait orientation)
  /LATEX    (LaTeX picture environment)
  /NULL     (Null device, no output)
  /PNG      (Portable Network Graphics file)
  /TPNG     (Portable Network Graphics file - transparent background)
  /PS       (PostScript file, landscape orientation)
  /VPS      (PostScript file, portrait orientation)
  /CPS      (Colour PostScript file, landscape orientation)
  /VCPS     (Colour PostScript file, portrait orientation)
Device Specification (? for list) :
```

- => Typing **/CPS + enter**, the program finishes and produces plots in colour, in a ps file and landscape orientation (called `pgplot.ps`)

The ESME simulation code

6) Typing `gv`
`pgplot.ps` & gives
the following result

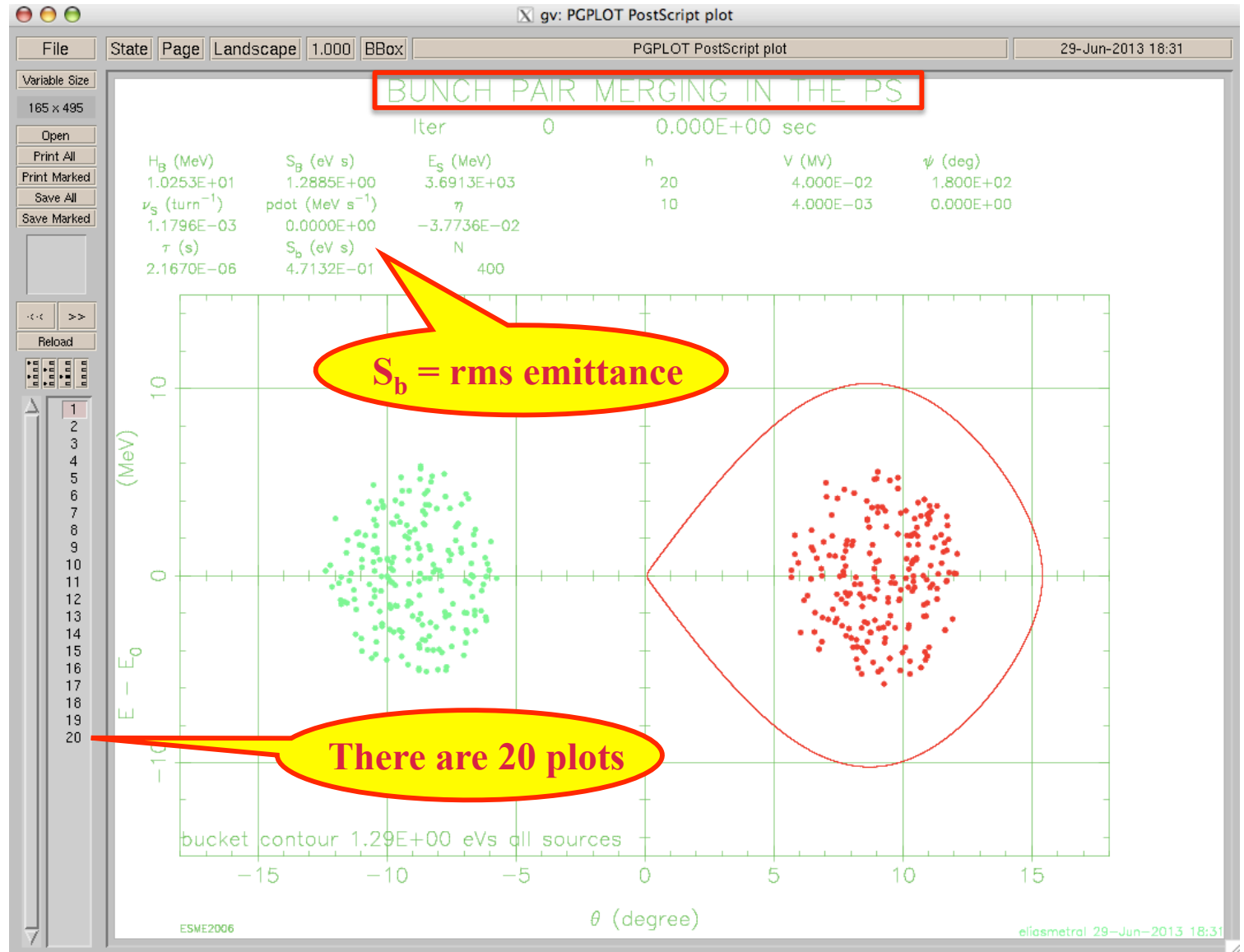

The ESME simulation code

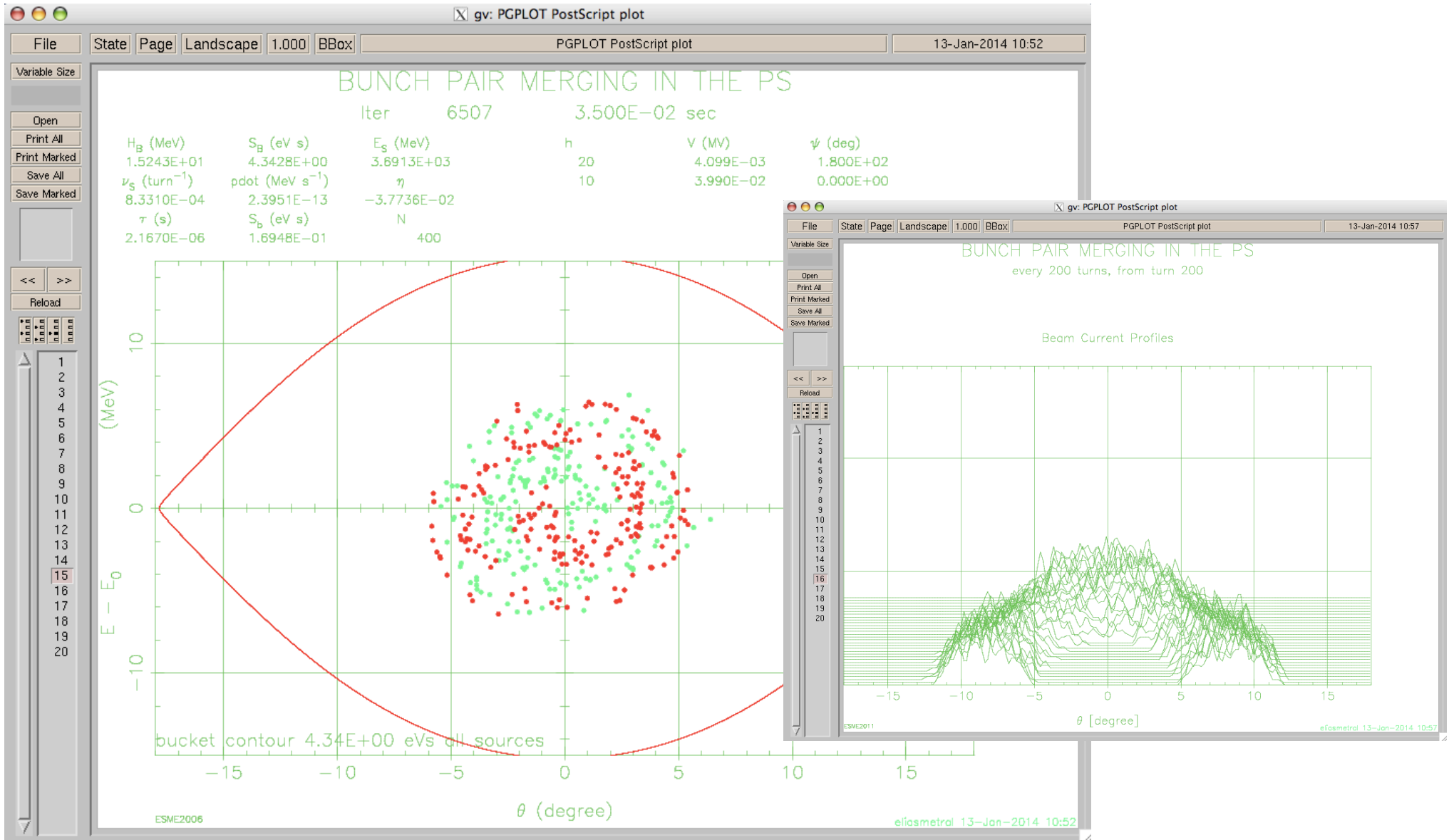

The ESME simulation code

Some info about the input file

Initialize memory for certain arrays according to input data

Write comment in output

Ring parameters

Acceleration (RF)

Populate phase space

Graphical Output

Display graphical Output

Track distribution

Select quantities to be plotted from History

Quit

```
docdat1.dat
I This memory allocation reduces the default allocation.
&MEMORY KNPHASE=2001 /END
W Test of adiabatic bunch pair merging in the PS
R CERN PS at 3.57 GeV/c
&RING REQ=100., GAMTSQ=37.21, W0I=2753., FRAC=5. KURVEB=0 /END
A h=20 and h=10 RF systems: turn down h=10 and turn up h=20 linearly.
&RF NRF=2 H=20,10 VI=40.E-3,4.E-3 VF=4.E-3,40.E-3 TVEND=0.0351,0.0351 KURVE=1,1
PSII=0.,-90. PSIF=0.,-90. TPBEG=0.,0. TPEND=.0351,.0351 KURVP=1,1 /END
P Parabolic bunch 1; center it in h=20 bucket. Distinguish it from bunch 2.
&POPL8 KIND=14 SBNCH=0.4 NPOINT=200 THOFF=-9. /END
P Parabolic bunch 2. Center in next h=20 bucket.
&POPL8 THOFF=9. /END
A RF for tracking. Only the phases have changed; everything else is the same.
&RF PSII=180.,0. PSIF=180.,0. &END
O Output format: Plot Delta E, Delta Theta scatter plot every 5000 turns.
&GRAPH MPlot=500 PLTSW(8)=.F. PLTSW(10)=.F.
IRF=0 THPMIN=-18. THPMAX=18. DEPMIN=-15. DEPMAx=15.
TITL='BUNCH PAIR MERGING IN THE PS' /END
D Plot at start.
M Set up Mountain Range for a trace every 200 turns.
&MRANGE MRMPLOT=200 IPU=T MRNBIN=200 MRBMIN=-18. MRBMAX=18. /END
T Tracking conditions: just go for 0.035 s.
&CYCLE TTRACK=0.035 RSCALE0=4.97 HISTRY=T /END
D
N Plot mountain range with two iterations of local smoothing
&MRPLOT
SMOOTH=-2 NTRACE=80 SCALE=0.2 MRPMIN=-18. MRPMAX=18.
/END
H
&HISTRY NPLT=1,14 1,18 1,6 1,10
/END
Q ESME stop.
```

M => Save azimuthal histograms for composition of a Mountain-range plot

N => Plot mountain-range data

The command character must be in its correct case, but parameter input is not case sensitive